



# Cutler-Hammer

## Transfer Switches

Technical Data TD01602016E

New Information



Automatic Transfer Switch Family

### Contents

#### Transfer Switch Equipment

Product Description . . . . .	2
Application Description . . . . .	2
Product Selection. . . . .	4
Manual Transfer Switches, 30 – 1000 Amperes . . . . .	6
Non-Automatic Switches, 30 – 4000 Amperes . . . . .	9
Maintenance Bypass Switches, 100 – 1000 Amperes . . . . .	12
Automatic (Wall Mount) Transfer Switches . . . . .	13
Floor-Standing Magnum Transfer Switches. . . . .	19
Magnum Bypass Isolation Transfer Switch . . . . .	24
Dimensions and Weights. . . . .	27
ATC-100 Controller. . . . .	31
ATC-300 Controller. . . . .	32
ATC-600 Controller. . . . .	33
ATC-800 Closed Transition Controller . . . . .	34
ATC Controller Selection Chart . . . . .	38
Standard and Optional Features for Automatic Transfer Switches . . . . .	47
Magnum Closed Transition Transfer Switch with Soft Load. . . . .	59
ATC-5000 Specifications . . . . .	67

## Transfer Switch Equipment

### Automatic Transfer Switches



Automatic Transfer Switch Family

#### Product Description

Eaton's Cutler-Hammer® Automatic Transfer Switches are reliable, rugged, versatile and compact assemblies for transferring essential loads and electrical distribution systems from one power source to another.

Transfer switches can be supplied in separate enclosures for stand-alone applications or can be supplied as an integral component in the following equipment:

- Magnum™ DS Switchgear.
- Pow-R-Line Switchboards.
- Motor Control Centers.
- Panelboards.

For detailed information on the aforementioned equipment, please see Eaton's 14th edition of the *Consulting Application Guide*.

#### Note:

For information on "Transfer Switch Panels," refer to **Section 4** of the *Distribution Products and Services* catalog "Advanced Residential Products."

#### Application Description

A transfer switch is a critical component of any emergency or standby power system. When the normal (preferred) source of power is lost, a transfer switch quickly and safely shifts the load circuit from the normal source of power to the emergency (alternate) source of power. This permits critical loads to continue running with minimal or no outage. After the normal source of power has been restored, the re-transfer process returns the load circuit to the normal power source.

Transfer switches are available with different operational modes including:

- Manual.
- Non-automatic.
- Automatic.
- Bypass isolation.
- Soft load.
- Maintenance bypass.

The power switching operation of transfer switches may be separated into the three (3) key categories of:

- Open Transition — Break-before-Make operation.
- Closed Transition — Make-before-Break operation.
- Closed Transition Soft Load — Both sources are paralleled and can remain so indefinitely.

The three (3) basic components of a transfer switch are:

- Power switching device to shift the load circuits to and from the power source.
- Transfer Logic Controller to monitor the condition of the power sources and provide the control signals to the power switching device.
- Control power source to supply operational power to the controller and switching device.

#### Typical Applications

All Eaton transfer switches are designed to meet the requirements set forth by UL® 1008, however, all transfer switches are not created equal. You can be assured of safe and reliable operation from all types of transfer switches that Eaton offers.

TABLE 1. UL 1008 ENDURANCE TESTING

ATS RATING (AMPERES)	RATE OF OPERATION PER MINUTE	WITH CURRENT	WITHOUT CURRENT	TOTAL
0 – 300	1	6000	—	6000
301 – 400	1	4000	—	4000
401 – 80	1	2000	1000	3000
801 – 1600	0.5	1500	1500	3000
1601 – 4000	0.25	1000	2000	3000

TABLE 2. UL 1008 LIFE EXPECTANCY

ATS RATING (AMPERES)	MINIMUM OPERATIONS PER YEAR	LIFE EXPECTANCY IN YEARS	
		WITH CURRENT APPLIED	WITHOUT CURRENT APPLIED
0 – 300	52	115	115
301 – 400	52	76	76
401 – 800	52	38	57
801 – 1600	52	28	57
1601 – 5000	52	19	57

#### UL 1008 Endurance Testing

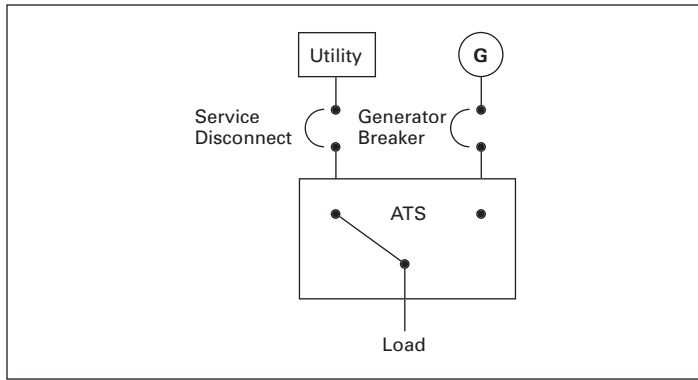
The importance of specifying a UL 1008 transfer switch can be seen in **Table 1**. When specifying any UL 1008 transfer switch, you can be assured the switch has met and passed the following endurance testing.

#### UL 1008 Life Expectancy

Transfer switch applications typically require a plant exerciser once a week or once a month. **Table 2** demonstrates the life expectancy operating the UL 1008 switch once a week for the life of the switch.

## Utility — Generator

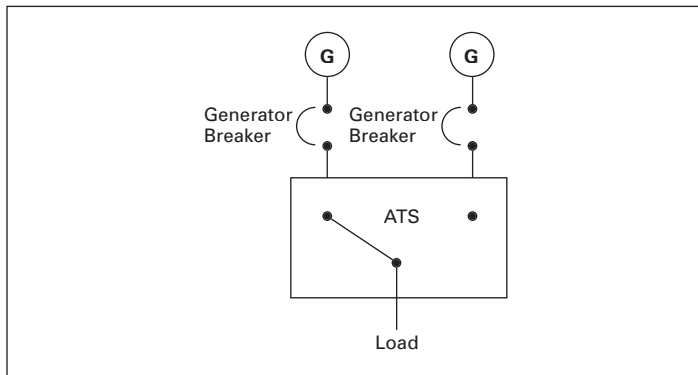
Transfer switches are traditionally applied between a utility and a generator set for emergency and standby power systems.



**FIGURE 1. STANDARD APPLICATION UTILITY — GENERATOR**

## Generator — Generator

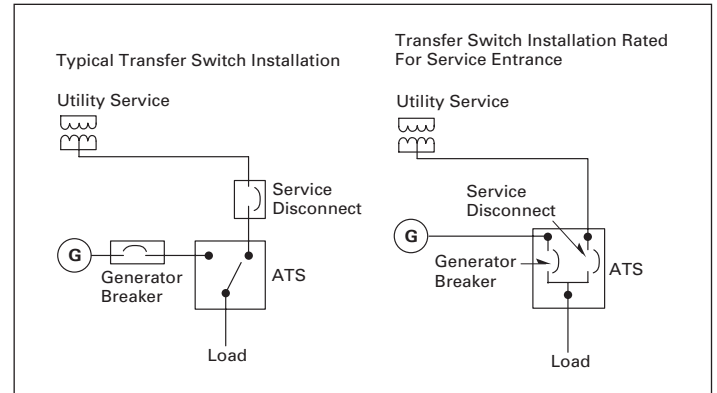
Transfer switches are sometimes applied between two generator sets for prime power use, often in remote installations. In such applications, source power is periodically alternated between the generator sets to equally share run-time.



**FIGURE 2. STANDARD APPLICATION GENERATOR — GENERATOR**

## Service Entrance Rated Transfer Switches

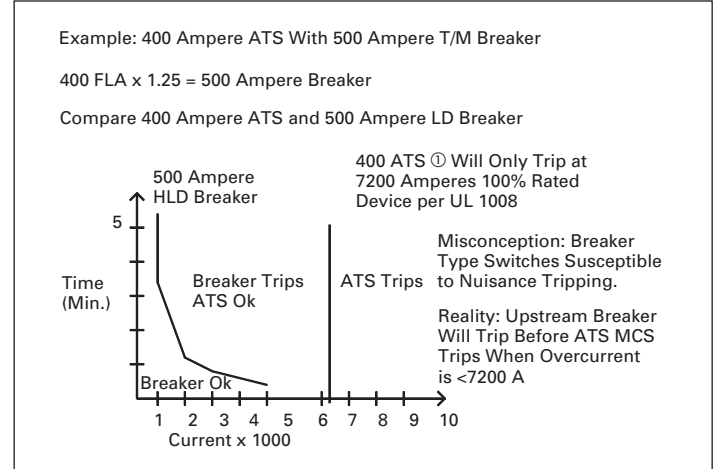
Modifying the molded case switch in the transfer switch by adding trip units and optional ground fault, along with adding the service entrance option eliminates the need for separate upstream disconnect devices and their respective power interconnections. This means the Automatic Transfer Switch (ATS) is installed directly at the point of service entrance, saving valuable space and cost.



**FIGURE 3. SERVICE ENTRANCE RATED TRANSFER SWITCHES**

## Built-in Protection

All Eaton Molded Case Switches are “self protected,” such that under extreme fault conditions, the switch will open before destroying itself. This feature allows Eaton to offer “Maintenance Free Contacts” on the molded case transfer switch. The molded case switches have instantaneous magnetic trip units installed in each switch. These trips are not accessible once installed by the factory to eliminate field tapering. The trips are set to a minimum of 12 to 15 times the rated current of the molded case device, well above any coordination set points. This means they will not interfere with the normal operation of the distribution system and will only trip if something is very wrong.








**FIGURE 4. BUILT-IN PROTECTION**

① Magnetic Trip 12 x frame rating.

TABLE 3. TRANSFER SWITCH PRODUCT FAMILY





TRANSFER SWITCH EQUIPMENT CATALOG NUMBERING SYSTEM

DESCRIPTION	TYPE	ORIENTATION	LOGIC	FRAME	SWITCH	POLES	AMPERES	VOLTAGE	ENCLOSURE	LISTING
	MT = Manual	H = Horizontal V = Vertical	X = No Logic	Molded Case Device FD = 30 – 150 A KD = 150 – 300 A LD = 400 – 600 A MD = 600 – 800 A NB = 800 – 1000 A	Fixed Mount A = FM, N(MCS) E(MCS) B = FM, N(MCB) E(MCB) C = FM, N(MCB) E(MCS) D = FM, N(MCS) E(MCB)	2 = 2-Poles 3 = 3-Poles 4 = 4-Poles	0030 = 30 A 0070 = 70 A 0100 = 100 A 0150 = 150 A 0225 = 225 A 0300 = 300 A 0400 = 400 A 0600 = 600 A 0800 = 800 A 1000 = 1000 A	E = 600 V 60 Hz	K = Open S = NEMA 1 J = NEMA 12 R = NEMA 3R L = NEMA 4 D = NEMA 4X	U = UL Listed R = UL Recognized X = No Listing
Manual (600 Vac) (30 – 1000 A)	Refer to Page 6									
	NT = Non-Auto-matic	H = Horizontal V = Vertical	E = Electro-mechanical	Molded Case Device FD = 30 – 150 A KD = 150 – 300 A LD = 400 – 600 A MD = 600 – 800 A NB = 800 – 1000 A  Insulated Case Device (Magnum) MG = 600 – 4000 A	Fixed Mount A = FM, N(M/MPS) E(M/MPS) B = FM, N(M/MPB) E(M/MPB) C = FM, N(M/MPB) E(M/MPS) D = FM, N(M/MPS) E(M/MPB)  Drawout Mount E = DO, N(MPS) E(MPS) F = DO, N(MPB) E(MPB) G = DO, N(MPB) E(MPS) H = DO, N(MPS) E(MPB)	2 = 2-Poles 3 = 3-Poles 4 = 4-Poles  (4-Poles – 3000 A Maximum)	0030 = 30 A 0070 = 70 A 0100 = 100 A 0150 = 150 A 0225 = 225 A 0300 = 300 A 0400 = 400 A 0600 = 600 A 0800 = 800 A 1000 = 1000 A 1200 = 1200 A 1600 = 1600 A 2000 = 2000 A 2500 = 2500 A 3000 = 3000 A 4000 = 4000 A 5000 = 5000 A	A = 120 V 60 Hz B = 208 V 60 Hz E = 600 V 60 Hz G = 220 V 50/60 Hz H = 380 V 50 Hz K = 600 V 50 Hz M = 230 V 50 Hz N = 401 V 50 Hz O = 415 V 50 Hz W = 240 V 60 Hz X = 480 V 60 Hz Z = 365 V 50 Hz	K = Open S = NEMA 1 J = NEMA 12 R = NEMA 3R L = NEMA 4 D = NEMA 4X (J, L and D 65 kAIC, 1200 A and Below Only)	U = UL Listed R = UL Recognized X = No Listing
Non-Automatic (600 Vac) (30 – 4000 A)	Refer to Page 9									
	MB = Maintenance Bypass	H = Horizontal	E = Electro-mechanical	Molded Case Device FD = 100 – 150 A KD = 150 – 300 A LD = 400 – 600 A MD = 600 – 800 A NB = 800 – 1000 A	Fixed Mount A = FM, N(MCS) E(MCS)	2 = 2 Poles 3 = 3 Poles 4 = 4 Poles	0100 = 100 A 0150 = 150 A 0225 = 225 A 0300 = 300 A 0400 = 400 A 0600 = 600 A 0800 = 800 A 1000 = 1000 A	A = 120 V 60 Hz B = 208 V 60 Hz E = 600 V 60 Hz G = 220 V 50/60 Hz H = 380 V 50 Hz K = 600 V 50 Hz M = 230 V 50 Hz N = 401 V 50 Hz O = 415 V 50 Hz W = 240 V 60 Hz X = 480 V 60 Hz Z = 365 V 50 Hz	K = Open S = NEMA 1 J = NEMA 12 R = NEMA 3R L = NEMA 4 D = NEMA 4X	U = UL Listed R = UL Recognized X = No Listing
Maintenance Bypass (600 Vac) (100 – 1000 A)	Refer to Page 12									
	AT = Auto-matic	H = Horizontal V = Vertical	3 = ATC-300 I = ATC-600	Molded Case Device FD = 30 – 200 A KD = 150 – 300 A LD = 400 – 600 A MD = 600 – 800 A NB = 800 – 1000 A  (FD = 200 A Available on ATH3 Only)	Fixed Mount A = FM, N(MCS) E(MCS) B = FM, N(MCB) E(MCB) C = FM, N(MCB) E(MCS) D = FM, N(MCS) E(MCB)	2 = 2-Poles 3 = 3-Poles 4 = 4-Poles	0030 = 30 A 0070 = 70 A 0100 = 100 A 0150 = 150 A 0200 = 200 A 0225 = 225 A 0300 = 300 A 0400 = 400 A 0600 = 600 A 0800 = 800 A 1000 = 1000 A	A = 120 V 60 Hz B = 208 V 60 Hz E = 600 V 60 Hz G = 220 V 50/60 Hz H = 380 V 50 Hz K = 600 V 50 Hz M = 230 V 50 Hz N = 401 V 50 Hz O = 415 V 50 Hz W = 240 V 60 Hz X = 480 V 60 Hz Z = 365 V 50 Hz	K = Open S = NEMA 1 J = NEMA 12 R = NEMA 3R L = NEMA 4 D = NEMA 4X	U = UL Listed R = UL Recognized X = No Listing
Automatic (Wall-Mount) (600 Vac) (30 – 1000 A)	Refer to Page 13									
	AT = Automatic	V = Vertical	I = ATC-600 IQ Transfer	Insulated Case Device (Magnum) MG = 600 – 5000 A	Fixed Mount A = FM, N(MPS) E(MPS) B = FM, N(MPB) E(MPB) C = FM, N(MPB) E(MPS) D = FM, N(MPS) E(MPB)  Drawout Mount E = DO, N(MPS) E(MPS) F = DO, N(MPB) E(MPB) G = DO, N(MPB) E(MPS) H = DO, N(MPS) E(MPB)	2 = 2 Poles 3 = 3 Poles 4 = 4 Poles  (4 Poles – 3000 A Maximum)	0600 = 600 A 0800 = 800 A 1000 = 1000 A 1200 = 1200 A 1600 = 1600 A 2000 = 2000 A 2500 = 2500 A 3000 = 3000 A 4000 = 4000 A 5000 = 5000 A  (600 A FM only)	A = 120 V 60 Hz B = 208 V 60 Hz E = 600 V 60 Hz G = 220 V 50/60 Hz H = 380 V 50 Hz K = 600 V 50 Hz M = 230 V 50 Hz N = 401 V 50 Hz O = 415 V 50 Hz W = 240 V 60 Hz X = 480 V 60 Hz Z = 365 V 50 Hz	S = NEMA 1 R = NEMA 3R	U = UL Listed R = UL Recognized X = No Listing
Automatic (Free Standing) (600 Vac) (600 – 5000 A)	Refer to Page 19									

Key: DO = Drawout                      MPB = Magnum Power Breaker                      MCB = Molded Case Breaker  
 FM = Fixed Mounted                      MPS = Magnum Power Switch                      MCS = Molded Case Switch

**TABLE 3. TRANSFER SWITCH PRODUCT FAMILY (CONTINUED)**

**TRANSFER SWITCH EQUIPMENT CATALOG NUMBERING SYSTEM**

DESCRIPTION	TYPE	ORIENTATION	LOGIC	FRAME	SWITCH	POLES	AMPERES	VOLTAGE	ENCLOSURE	LISTING
 Automatic Closed Transition (<100 ms) (600 Vac) (600 – 5000 A)	CT = Closed Transition	V = Vertical	I = ATC-800 Closed Transition IQ Transfer	Device (Magnum) MG = 600 – 5000 A	Fixed Mount A = FM, N(MPS) E(MPS) B = FM, N(MPB) E(MPB) C = FM, N(MPB) E(MPS) D = FM, N(MPS) E(MPB)  Drawout Mount E = DO, N(MPS) E(MPS) F = DO, N(MPB) E(MPB) G = DO, N(MPB) E(MPS) H = DO, N(MPS) E(MPB)	2 = 2-Poles 3 = 3-Poles 4 = 4-Poles  (4 Poles – 3000 A Maximum)	0600 = 600 A 0800 = 800 A 1000 = 1000 A 1200 = 1200 A 1600 = 1600 A 2000 = 2000 A 2500 = 2500 A 3000 = 3000 A 4000 = 4000 A 5000 = 5000 A  (600 A FM Only)	A = 120 V 60 Hz B = 208 V 60 Hz E = 600 V 60 Hz G = 220 V 50/60 Hz H = 380 V 50 Hz K = 600 V 50 Hz M = 230 V 50 Hz N = 401 V 50 Hz O = 415 V 50 Hz W = 240 V 60 Hz X = 480 V 60 Hz Z = 365 V 50 Hz	S = NEMA 1 R = NEMA 3R	U = UL 1008 Listed R = UL Recognized Z = UL 891 Listed X = No Listing
 Bypass Isolation (600 Vac) (800 – 5000 A)	BI = Bypass Isolation	V = Vertical	I = ATC-600	Device (Magnum) MG = 200 – 5000 A	Drawout Mount E = DO, N(MPS) E(MPS) F = DO, N(MPB) E(MPB) G = DO, N(MPS) E(MPS) H = DO, N(MPS) E(MPB)	2 = 2-Poles 3 = 3-Poles 4 = 4-Poles  (4 Poles – 3000 A Maximum)	0200 = 200 A 1000 = 1000 A 1200 = 1200 A 1600 = 1600 A 2000 = 2000 A 2500 = 2500 A 3000 = 3000 A 4000 = 4000 A 5000 = 5000 A	A = 120 V 60 Hz B = 208 V 60 Hz E = 600 V 60 Hz G = 220 V 50/60 Hz H = 380 V 50 Hz K = 600 V 50 Hz M = 230 V 50 Hz N = 401 V 50 Hz O = 415 V 50 Hz W = 240 V 60 Hz X = 480 V 60 Hz Z = 365 V 50 Hz	S = NEMA 1 R = NEMA 3R	U = UL 1008 Listed R = UL Recognized Z = UL 891 Listed X = No Listing
 Closed Transition Bypass Isolation (<100 ms) (600 Vac) (800 – 5000 A)	CB = Closed Transition Bypass Isolation	V = Vertical	I = ATC-800 Closed Transition IQ Transfer	Device (Magnum) MG = 600 – 5000 A	Drawout Mount E = DO, N(MPS) E(MPS) F = DO, N(MPB) E(MPB) G = DO, N(MPB) E(MPS) H = DO, N(MPS) E(MPB)	2 = 2-Poles 3 = 3-Poles 4 = 4-Poles  (4 Poles – 3000 A Maximum)	0800 = 800 A 1000 = 1000 A 1200 = 1200 A 1600 = 1600 A 2000 = 2000 A 2500 = 2500 A 3000 = 3000 A 4000 = 4000 A 5000 = 5000 A	A = 120 V 60 Hz B = 208 V 60 Hz E = 600 V 60 Hz G = 220 V 50/60 Hz H = 380 V 50 Hz K = 600 V 50 Hz M = 230 V 50 Hz N = 401 V 50 Hz O = 415 V 50 Hz W = 240 V 60 Hz X = 480 V 60 Hz Z = 365 V 50 Hz	S = NEMA 1 R = NEMA 3R	U = UL 1008 Listed R = UL Recognized Z = UL 891 Listed X = No Listing
 Closed Transition Soft Load (600 Vac) (800 – 5000 A)	CT = Closed Transition Soft Load	V = Vertical	C = Soft Load P = Soft Load Parallel Source	Device (Magnum) MG = 600 – 5000 A	Fixed Mount A = FM, N(MPS) E(MPS) B = FM, N(MPB) E(MPB) C = FM, N(MPB) E(MPS) D = FM, N(MPS) E(MPB)  Drawout Mount E = DO, N(MPS) E(MPS) F = DO, N(MPB) E(MPB) G = DO, N(MPB) E(MPS) H = DO, N(MPS) E(MPB)	2 = 2-Poles 3 = 3-Poles 4 = 4-Poles  (4 Poles – 3000 A Maximum)	0800 = 800 A 1000 = 1000 A 1200 = 1200 A 1600 = 1600 A 2000 = 2000 A 2500 = 2500 A 3000 = 3000 A 4000 = 4000 A 5000 = 5000 A	A = 120 V 60 Hz B = 208 V 60 Hz E = 600 V 60 Hz G = 220 V 50/60 Hz H = 380 V 50 Hz K = 600 V 50 Hz M = 230 V 50 Hz N = 401 V 50 Hz O = 415 V 50 Hz W = 240 V 60 Hz X = 480 V 60 Hz Z = 365 V 50 Hz	S = NEMA 1 R = NEMA 3R (NEMA 3R Walk-In or Non-Walk-In)	U = UL 1008 Listed R = UL Recognized Z = UL 891 Listed X = No Listing

**Key:** DO = Drawout  
FM = Fixed Mounted

MPB = Magnum Power Breaker  
MPS = Magnum Power Switch

MCB = Molded Case Breaker  
MCS = Molded Case Switch

## Molded Case Switches — Manual Wall-Mount



Manual Wall-Mount Transfer Switch

### Product Description

Eaton's Cutler-Hammer Wall-Mount manually operated transfer switches are designed for a variety of standby power applications for critical loads. In the event of a primary power source interruption, the user can manually transfer the load circuits to the standby power source. Once primary power has been restored, the user can manually transfer the load circuits back to the primary power source.

### Application Description

Manual transfer switches cover applications ranging from 30 to 1000 amperes through 600 Vac, for standard manual configurations, and open transition.

### Features, Benefits and Functions

#### Features

- Molded case switch power contact assemblies.
- Positive mechanical interlocking.
- Permanently affixed manual operating handle.

### Benefits

- High withstand, totally enclosed for maximum arc suppression and isolation during power transfer.
- Optional trip units offer system overcurrent protection.
- Prevents the paralleling of two sources of power.
- Permits safe and convenient manual transfer of power.

### Standards and Certifications

- Complies with UL 1008 and UL 489 standards.
- IBC seismic qualified.
- Meets American Bureau of Shipping (ABS) approval.

### Technical Data and Specifications

TABLE 4. WALL-MOUNT TRANSFER SWITCH STANDARD TERMINAL DATA FOR POWER CABLE CONNECTIONS

SWITCH AMPERE RATING	BREAKER FRAME	LINE SIDE (NORMAL AND STANDBY SOURCE)	LOAD CONNECTION	NEUTRAL CONNECTION
30 – 100	HFD	(1) #14 – 1/0	(1) #14 – 1/0	(3) #14 – 1/0
150 – 225	HFD	(1) #6 – 300	(1) #6 – 300	(3) #4 – 300
225 – 300	HKD	(1) #3 – 350	(1) #6 – 350	(3) #4 – 350
400	HLD	(1) 4/0 – 600	(2) #1 – 500	(6) 250 – 350
600	HLD	(1) 3/0 – 350	(2) #1 – 500	(6) 250 – 350
600	HMDL	(2) #1 – 500	(2) #1 – 500	(12) 4/0 – 500
600 (4-Pole)	NB	(3) 3/0 – 400	(3) 3/0 – 400	(3) 3/0 – 400
800	HMDL	(3) 3/0 – 400	(3) 3/0 – 400	(12) 4/0 – 500
800	HNB	(4) 4/0 – 500	(4) 4/0 – 500	(12) 4/0 – 500
1000	HNB	(4) 4/0 – 500	(4) 4/0 – 500	(12) 4/0 – 500

#### Note:

All terminals suitable for copper or aluminum conductors.

#### Note:

For alternate terminal sizes, contact Eaton.

TABLE 5. TRANSFER SWITCH RATINGS — SYSTEMS COORDINATION INFORMATION — WITHSTAND, CLOSING AND INTERRUPTING RATINGS <sup>①</sup>

#### STANDARD UL 1008 3-CYCLE — HORIZONTAL AND VERTICAL INDUSTRIAL

ATS AMPERE RATING	ANY BREAKER RATING			RATINGS WHEN USED WITH UPSTREAM FUSE (KA)		
	240 VOLTS	480 VOLTS	600 VOLTS	MAXIMUM FUSE RATING	FUSE TYPE <sup>②</sup>	600 VOLTS
30	100	65	25	200	J, T	200
70	100	65	25	200	J, T	200
100	100	65	25	200	J, T	200
150	100	65	25	400	J, T	200
200	100	65	25	400	J, T	200
225	100	65	25	400	J, T	200
300	100	65	25	400	J, T	200
400	100	65	25	600	J, T	200
600	100	65 <sup>③</sup>	25	800/1200	J, T	100/200
800	65	50 <sup>③</sup>	25	1200/1600	L	100/200
1000	65	50 <sup>③</sup>	25	1600	L	200

<sup>①</sup> For maximum breaker ratings in circuits when the transfer switch is evaluated as a "Motor Branch Circuit Conductor," refer to NEC Section 430-25 for sizing.

<sup>②</sup> Class RK5 fuse with 100 kA rating.

<sup>③</sup> 4-pole units rated 35 kA.

Layout Dimensions

TABLE 6. 30 – 1000 AMPERE TYPE MTVX DIMENSIONS IN INCHES (MM) AND APPROXIMATE SHIPPING WEIGHTS

SWITCH TYPE	ENCLOSURE			GUTTER SPACE			BOLT PATTERN		STANDARD TERMINALS ①			WEIGHT LBS. (KG)
	A	B	C	D	E	F	G	H	LINE	LOAD	NEUTRAL	
HKD (150 – 225 A)	48.00 (1219.2)	20.81 (528.6)	18.40 (467.4)	8.00 (203.2)	4.00 (101.6)	10.59 (269.0)	11.00 (279.4)	45.50 (1155.7)	(1) #3 – 350	(1) #6 – 350	(3) #4 – 350	305 (138)
HLD (300 A)	56.00 (1422.4)	20.81 (528.6)	18.40 (467.4)	8.00 (203.2)	4.00 (101.6)	13.59 (345.2)	11.00 (279.4)	53.50 (1358.9)	(1) #3 – 350	(1) #6 – 350	(3) #4 – 350	395 (179)
HLD (400 A)	64.00 (1625.6)	25.81 (655.6)	18.40 (467.4)	8.00 (203.2)	4.00 (101.6)	10.54 (267.7)	16.00 (406.4)	61.48 (1561.6)	(1) 4/0 – 600	(2) #1 – 500	(6) 250 – 350	395 (179)
HLD (400 A) ②	53.00 (1346.2)	25.81 (655.6)	18.40 (467.4)	8.00 (203.2)	4.00 (101.6)	11.85 (301.0)	16.00 (406.4)	50.48 (1282.2)	(2) 3/0 – 350	(2) #1 – 500	(6) 250 – 350	395 (179)
HLD (600 A)	64.00 (1625.6)	25.81 (655.6)	18.40 (467.4)	8.00 (203.2)	4.00 (101.6)	10.54 (267.7)	16.00 (406.4)	61.48 (1561.6)	(2) 3/0 – 350	(2) #1 – 500	(12) 4/0 – 500	395 (179)
HLD (600 A) ②	64.00 (1625.6)	25.81 (655.6)	18.40 (467.4)	8.00 (203.2)	4.00 (101.6)	10.54 (267.7)	16.00 (406.4)	61.48 (1561.6)	(2) 400 – 500	(2) #1 – 500	(12) 4/0 – 500	395 (179)
HMDL (600 A)	76.74 (1949.2)	25.81 (655.6)	19.50 (495.3)	8.00 (203.2)	4.00 (101.6)	17.73 (450.3)	16.00 (406.4)	75.15 (1908.8)	(2) #1 – 500	(2) #1 – 500	(12) 4/0 – 500	510 (232)
HMDL (800 A)	76.74 (1949.2)	25.81 (655.6)	19.50 (495.3)	8.00 (203.2)	4.00 (101.6)	17.73 (450.3)	16.00 (406.4)	75.15 (1908.8)	(3) 3/0 – 400	(3) 3/0 – 400	(12) 4/0 – 500	510 (232)
NB (800 – 1000 A)	76.74 (1949.2)	25.81 (655.6)	19.50 (495.3)	8.00 (203.2)	4.00 (101.6)	17.58 (446.5)	16.00 (406.4)	75.15 (1908.8)	(4) 4/0 – 500	(4) 4/0 – 500	(12) 4/0 – 500	540 (245)

① Suitable for Cu or Al wire. Consult the factory for other available terminal sizes.  
 ② Alternate line terminals.

TABLE 7. 30 – 150 AMPERES TYPE MTHXFD MANUAL DIMENSIONS IN INCHES (MM) AND WEIGHTS LBS. (KG)

30 – 150 AMPERES DIMENSIONS								WEIGHT LBS. (KG)
A	B	C	D	E	F	G	H	
22.88 (581.2)	13.13 (333.5)	22.74 (577.6)	22.62 (574.5)	24.50 (622.3)	9.78 (248.4)	10.28 (261.1)	32.31 (820.7)	143 (65)

TABLE 8. POWER PANEL AND TRANSFORMER PANEL DIMENSIONS IN INCHES (MM)

POWER PANEL TYPE	DIMENSIONS		
	HEIGHT	WIDTH	DEPTH
<b>Power Panel</b>			
HFD	11.00 (279.4)	17.00 (431.8)	6.81 (173.0)
HKD	24.50 (622.3)	11.88 (301.8)	17.50 (444.5)
HLD	26.00 (660.4)	16.88 (428.8)	17.50 (444.5)
HMDL	36.25 (920.8)	16.88 (428.8)	17.50 (444.5)
NB	36.25 (920.8)	16.88 (428.8)	19.00 (482.6)
<b>Transformer Panel</b>			
HFD	22.00 (558.8)	16.50 (419.1)	6.50 (165.1)
HKD, HLD, HMDL and NB	28.63 (727.2)	8.25 (209.6)	5.50 (139.7)

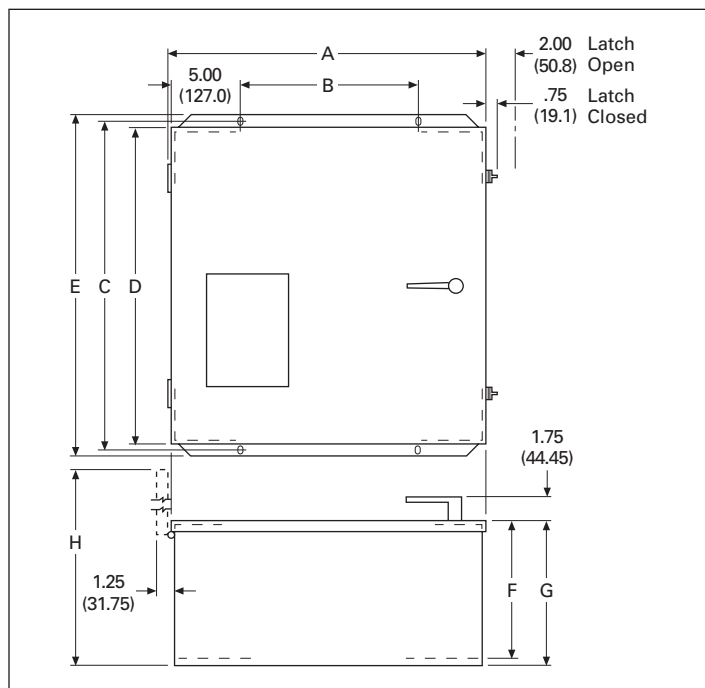


FIGURE 5. DIMENSIONS

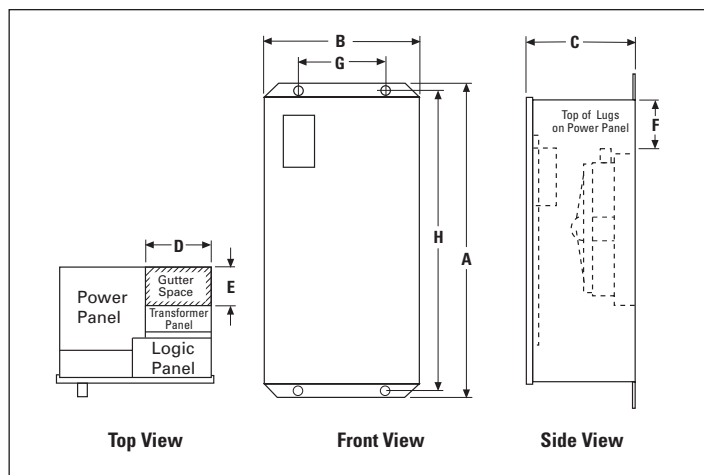
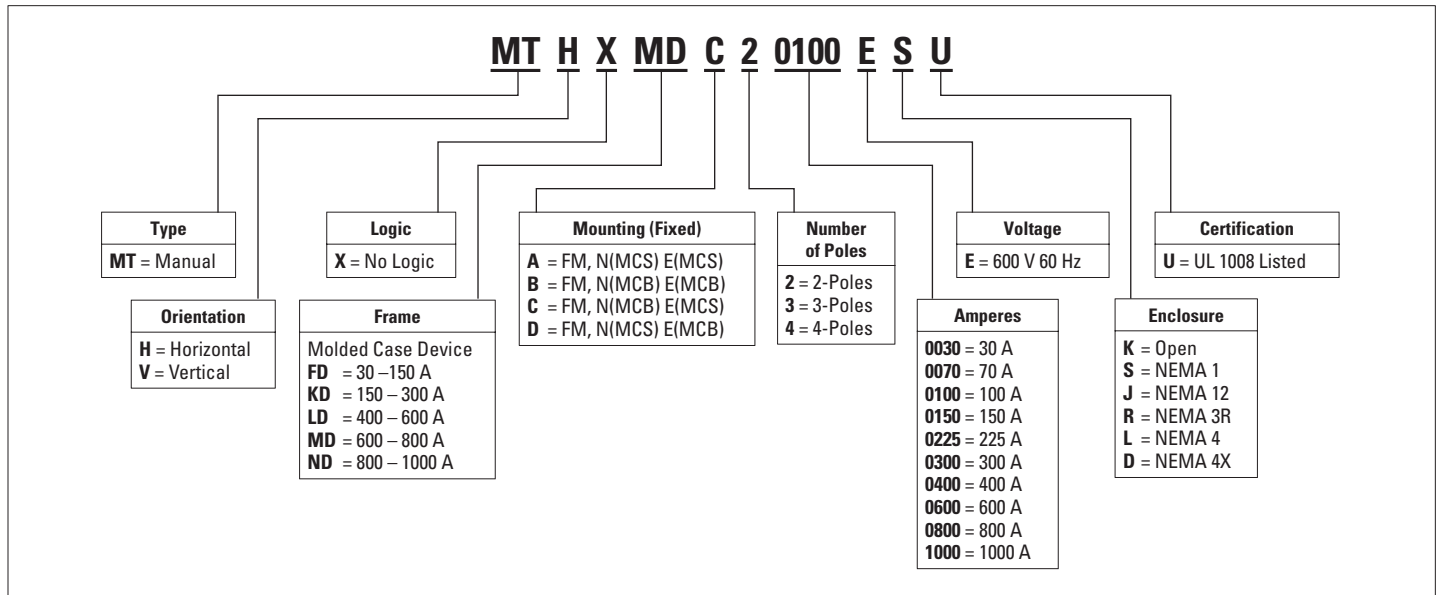


FIGURE 6. DIMENSIONS

Dimensions are approximate in inches (mm).  
 Should not be used for construction purposes.

TABLE 9. MANUAL WALL-MOUNT TRANSFER SWITCH CATALOG NUMBERING SYSTEM



## Molded Case Switches — Non-Automatic Wall-Mount



*Non-Automatic Wall-Mount*

### Product Description

Eaton's Cutler-Hammer Wall-Mount Non-Automatic Transfer Switches are designed for a variety of standby power applications for critical loads.

In the event of a primary power source interruption, the user can manually transfer the load circuits to the standby power source through the use of an external pushbutton. Once primary power has been restored, the user can manually transfer the load circuits back to the primary power source through the use of an external pushbutton.

### Application Description

Non-Automatic transfer switches cover applications ranging from 30 to 1000 amperes through 600 Vac, for manual configurations, open transition, standard or service entrance.

### Features, Benefits and Functions

#### Features

- Molded case switch power contact assemblies.
- Positive mechanical and electrical interlocking.
- Permanently affixed manual operating handle.
- Pushbutton operation.

#### Benefits

- High withstand, totally enclosed for maximum arc suppression and isolation during power transfer.
- Optional trip units offer system overcurrent protection.
- Prevents the paralleling of two sources of power.
- Permits safe and convenient manual transfer of power under load via external pushbutton initiated operation.

### Standards and Certifications

- Complies with UL 1008 and UL 489 standards.
- IBC seismic qualified.
- Meets American Bureau of Shipping (ABS) approval.

## Technical Data and Specifications

**TABLE 10. WALL-MOUNT TRANSFER SWITCH STANDARD TERMINAL DATA FOR POWER CABLE CONNECTIONS**

SWITCH AMPERE RATING	BREAKER FRAME	LINE SIDE (NORMAL AND STANDBY SOURCE)	LOAD CONNECTION	NEUTRAL CONNECTION
30 – 100	HFD	(1) #14 – 1/0	(1) #14 – 1/0	(3) #14 – 1/0
150 – 225	HFD	(1) #6 – 300	(1) #6 – 300	(3) #4 – 300
225 – 300	HKD	(1) #3 – 350	(1) #6 – 350	(3) #4 – 350
400	HLD	(1) 4/0 – 600	(2) #1 – 500	(6) 250 – 350
600	HLD	(1) 3/0 – 350	(2) #1 – 500	(6) 250 – 350
600	HMDL	(2) #1 – 500	(2) #1 – 500	(12) 4/0 – 500
600 (4-Pole)	NB	(3) 3/0 – 400	(3) 3/0 – 400	(3) 3/0 – 400
800	HMDL	(3) 3/0 – 400	(3) 3/0 – 400	(12) 4/0 – 500
800	HNB	(4) 4/0 – 500	(4) 4/0 – 500	(12) 4/0 – 500
1000	HNB	(4) 4/0 – 500	(4) 4/0 – 500	(12) 4/0 – 500

#### Note:

All terminals suitable for copper or aluminum conductors.

#### Note:

For alternate terminal sizes, contact Eaton.

**TABLE 11. TRANSFER SWITCH RATINGS — SYSTEMS COORDINATION INFORMATION — WITHSTAND, CLOSING AND INTERRUPTING RATINGS ①**

#### STANDARD UL 1008 3-CYCLE — HORIZONTAL AND VERTICAL INDUSTRIAL

ATS AMPERE RATING	ANY BREAKER RATING			RATINGS WHEN USED WITH UPSTREAM FUSE (KA)		
	240 VOLTS	480 VOLTS	600 VOLTS	MAXIMUM FUSE RATING	FUSE TYPE ②	600 VOLTS
30	100	65	25	200	J, T	200
70	100	65	25	200	J, T	200
100	100	65	25	200	J, T	200
150	100	65	25	400	J, T	200
200	100	65	25	400	J, T	200
225	100	65	25	400	J, T	200
300	100	65	25	400	J, T	200
400	100	65	25	600	J, T	200
600	100	65 ③	25	800/1200	J, T	100/200
800	65	50 ③	25	1200/1600	L	100/200
1000	65	50 ③	25	1600	L	200

① For maximum breaker ratings in circuits when the transfer switch is evaluated as a "Motor Branch Circuit Conductor," refer to NEC Section 430-25 for sizing.

② Class RK5 fuse with 100 kA rating.

③ 4-pole units rated 35 kA.

## Layout Dimensions

**TABLE 12. 30 – 1000 AMPERE TYPES NTHE, NTVE DIMENSIONS IN INCHES (MM) AND APPROXIMATE SHIPPING WEIGHTS**

SWITCH TYPE	ENCLOSURE			GUTTER SPACE			BOLT PATTERN		STANDARD TERMINALS ①			WEIGHT LBS. (KG)
	A	B	C	D	E	F	G	H	LINE	LOAD	NEUTRAL	
HFD (30 – 100 A) ②	47.74 (1213.0)	20.81 (528.6)	17.22 (437.0)	8.00 (203.2)	4.00 (101.6)	6.22 (157.9)	10.75 (273.0)	45.24 (1049.1)	(1) #14 – 1/0	(1) #14 – 1/0	(3) #14 – 1/0	227 (103)
HFD (150 A) ②	47.74 (1213.0)	20.81 (528.6)	17.22 (437.0)	8.00 (203.2)	4.00 (101.6)	6.22 (157.9)	10.75 (273.0)	45.24 (1049.1)	(1) #6 – 300	(1) #6 – 300	(3) #4 – 300	227 (103)
HKD (150 – 225 A)	48.00 (1219.2)	20.81 (528.6)	18.40 (467.4)	8.00 (203.2)	4.00 (101.6)	10.59 (269.0)	11.00 (279.4)	45.50 (1155.7)	(1) #3 – 350	(1) #6 – 350	(3) #4 – 350	305 (138)
HKD (300 A)	56.00 (1422.4)	20.81 (528.6)	18.40 (467.4)	8.00 (203.2)	4.00 (101.6)	13.59 (345.2)	11.00 (279.4)	53.50 (1358.9)	(1) #3 – 350	(1) #6 – 350	(3) #4 – 350	395 (179)
HLD (400 A)	64.00 (1625.6)	25.81 (655.6)	18.40 (467.4)	8.00 (203.2)	4.00 (101.6)	10.54 (267.7)	16.00 (406.4)	61.48 (1561.6)	(1) 4/0 – 600	(2) #1 – 500	(6) 250 – 350	395 (179)
HLD (400 A) ③	53.00 (1346.2)	25.81 (655.6)	18.40 (467.4)	8.00 (203.2)	4.00 (101.6)	11.85 (301.0)	16.00 (406.4)	50.48 (1282.2)	(2) 3/0 – 350	(2) #1 – 500	(6) 250 – 350	395 (179)
HLD (600 A)	64.00 (1625.6)	25.81 (655.6)	18.40 (467.4)	8.00 (203.2)	4.00 (101.6)	10.54 (267.7)	16.00 (406.4)	61.48 (1561.6)	(2) 3/0 – 350	(2) #1 – 500	(12) 4/0 – 500	395 (179)
HLD (600 A) ③	64.00 (1625.6)	25.81 (655.6)	18.40 (467.4)	8.00 (203.2)	4.00 (101.6)	10.54 (267.7)	16.00 (406.4)	61.48 (1561.6)	(2) 400 – 500	(2) #1 – 500	(12) 4/0 – 500	395 (179)
HMDL (600 A)	76.74 (1949.2)	25.81 (655.6)	19.50 (495.3)	8.00 (203.2)	4.00 (101.6)	17.73 (450.3)	16.00 (406.4)	75.15 (1908.8)	(2) #1 – 500	(2) #1 – 500	(12) 4/0 – 500	510 (232)
HMDL (800 A)	76.74 (1949.2)	25.81 (655.6)	19.50 (495.3)	8.00 (203.2)	4.00 (101.6)	17.73 (450.3)	16.00 (406.4)	75.15 (1908.8)	(3) 3/0 – 400	(3) 3/0 – 400	(12) 4/0 – 500	510 (232)
NB (800 – 1000 A)	76.74 (1949.2)	25.81 (655.6)	19.50 (495.3)	8.00 (203.2)	4.00 (101.6)	17.58 (446.5)	16.00 (406.4)	75.15 (1908.8)	(4) 4/0 – 500	(4) 4/0 – 500	(12) 4/0 – 500	540 (245)

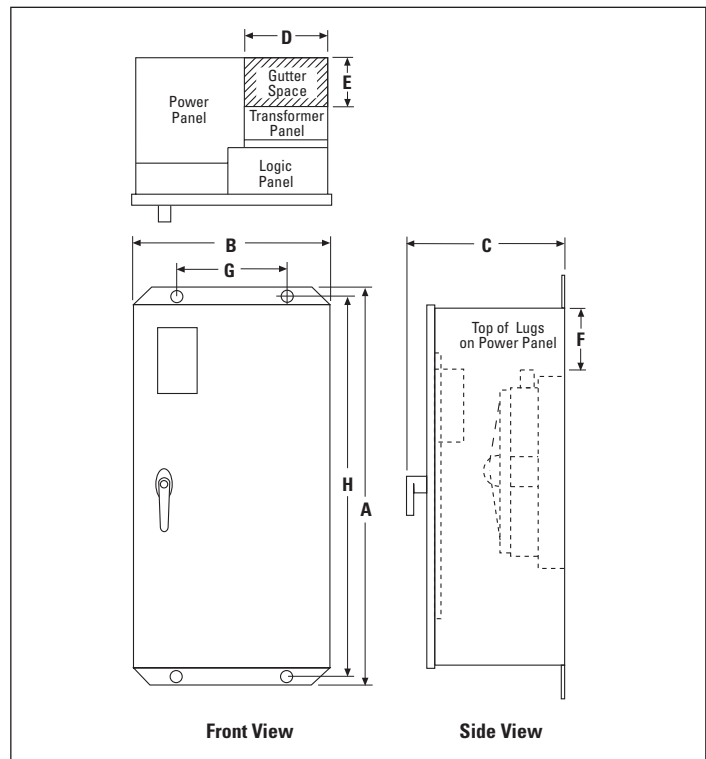
① Suitable for Cu or Al wire. Consult the factory for other available terminal sizes.

② NTHE with multi-tap voltage selection panel.

③ Alternate line terminals.

**TABLE 13. POWER PANEL AND TRANSFORMER PANEL DIMENSIONS IN INCHES (MM)**

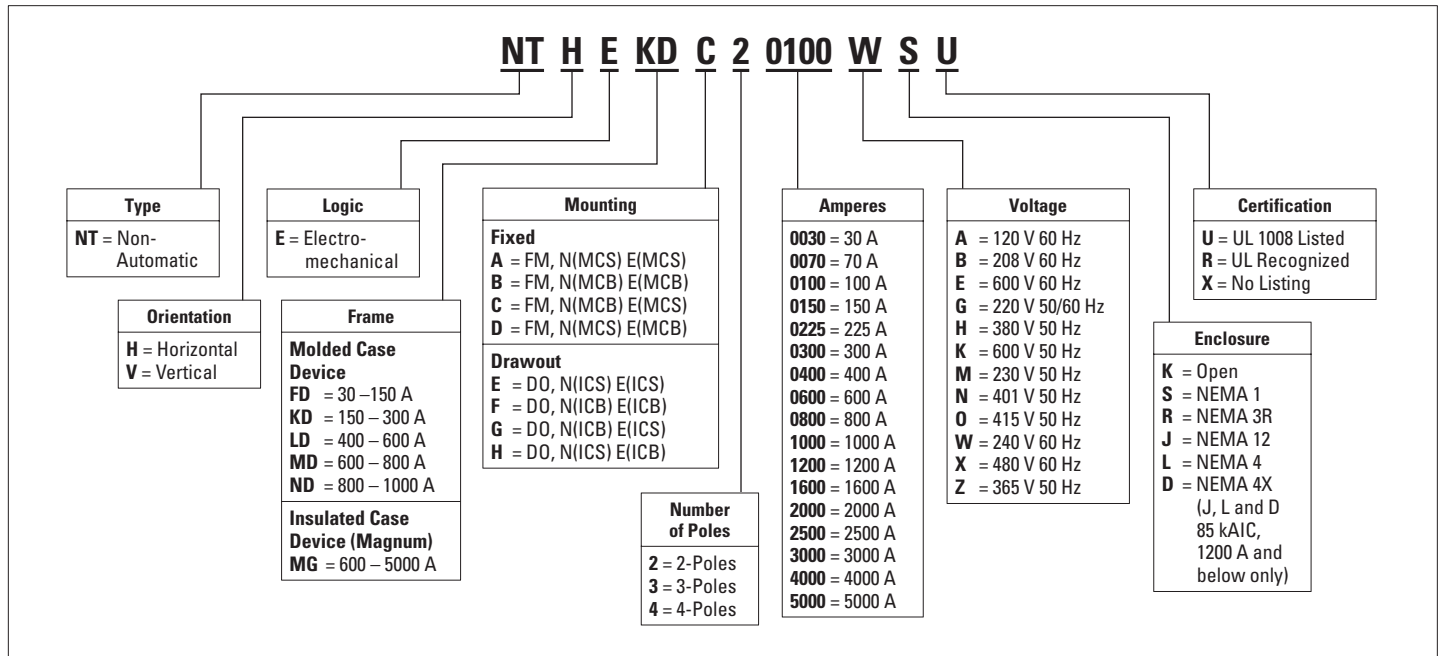
POWER PANEL TYPE	DIMENSIONS		
	HEIGHT	WIDTH	DEPTH
<b>Power Panel</b>			
HFD	11.00 (279.4)	17.00 (431.8)	6.81 (173.0)
HKD	24.50 (622.3)	11.88 (301.8)	17.50 (444.5)
HLD	26.00 (660.4)	16.88 (428.8)	17.50 (444.5)
HMDL	36.25 (920.8)	16.88 (428.8)	17.50 (444.5)
NB	36.25 (920.8)	16.88 (428.8)	19.00 (482.6)
<b>Transformer Panel</b>			
HFD	22.00 (558.8)	16.50 (419.1)	6.50 (165.1)
HKD, HLD, HMDL and NB	28.63 (727.2)	8.25 (209.6)	5.50 (139.7)



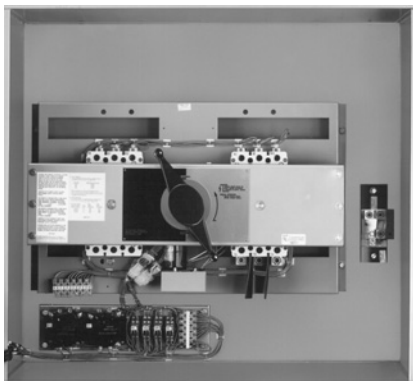
**FIGURE 7. DIMENSIONS**

Dimensions are approximate in inches (mm).  
Should not be used for construction purposes.

TABLE 14. NON-AUTOMATIC WALL-MOUNT TRANSFER SWITCH CATALOG NUMBERING SYSTEM



## Maintenance Bypass Switches Type MBHE 100 – 1000 Amperes



Type MBHE Maintenance Bypass Switch

### General Description

Eaton's Cutler-Hammer Maintenance Bypass Switch is a UL 1008 listed device that provides a simple and effective means for bypassing un-interruptible power supplies while maintaining continuity of power to the critical computer loads. A maintenance bypass switch is a requirement on every UPS installation in order to accommodate the maintenance and testing of the UPS system.

### Features

- UL 1008 listing — File E61639.
- Make-before-break electrical operation.
- Lockout circuit to be wired into the UPS bypass authorization.
- Pilot devices to show UPS position "Normal" and "Bypassed."
- Pilot device to show "Lockout" enabled.
- Reliable manually initiated electrical operation.
- High interrupting ratings are standard.
- Molded case switch designs are available.
- Solid neutral connections are standard.

### Benefits

- Safe and reliable operation is ensured due to the simple and durable switching design.
- Unauthorized bypass is prevented by the need of UPS system to send the bypass authorized signal.
- 100% current ratings makes selection to the UPS kVA ratings easy to accomplish.
- Use of interrupting rating switches makes the maintenance bypass switches adaptable to systems with high levels of available fault current.

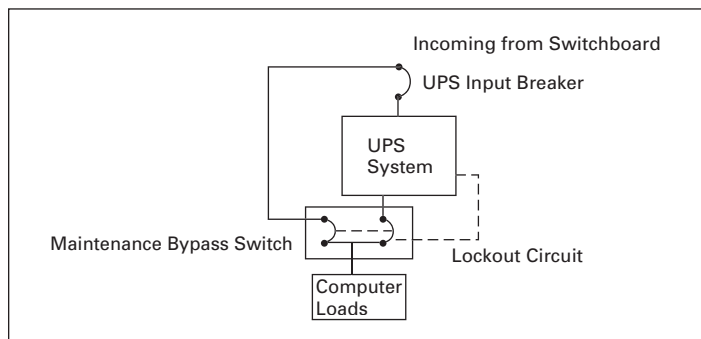


FIGURE 8. SINGLE LINE DIAGRAM OF MAINTENANCE BYPASS SWITCH

Dimensions are approximate in inches (mm).  
Should not be used for construction purposes

## Layout Dimensions

### Manual Transfer and Maintenance Bypass Switches

100 – 150 Amperes Type MTHXFD Manual /100 – 1000 Amperes Type MBHE Maintenance Bypass

TABLE 15. MANUAL AND MAINTENANCE BYPASS ENCLOSURES — DIMENSIONS IN INCHES (MM)

AMPERES	DIMENSIONS							
	A	B	C	D	E	F	G	H
100 – 150	22.88 (581.2)	13.13 (333.5)	22.74 (577.6)	22.62 (574.5)	24.50 (622.3)	9.78 (248.4)	10.28 (261.1)	32.31 (820.7)
225 – 300	38.88 (987.6)	29.13 (739.9)	35.74 (907.8)	35.62 (904.7)	37.50 (952.5)	17.28 (438.9)	17.78 (438.9)	55.81 (1417.6)
400	38.88 (987.6)	29.13 (739.9)	35.74 (907.8)	35.62 (904.7)	37.50 (952.5)	17.28 (438.9)	17.78 (438.9)	55.81 (1417.6)
600	38.88 (987.6)	29.13 (739.9)	49.74 (1263.4)	49.62 (1260.3)	51.50 (1308.1)	17.28 (438.9)	17.78 (438.9)	55.81 (1417.6)
800	38.88 (987.6)	29.13 (739.9)	49.74 (1263.4)	49.62 (1260.3)	51.50 (1308.1)	17.28 (438.9)	17.78 (438.9)	55.81 (1417.6)
1000	38.88 (987.6)	29.13 (739.9)	59.74 (1517.4)	59.62 (1514.3)	61.50 (1562.1)	17.28 (438.9)	17.78 (438.9)	55.81 (1417.6)

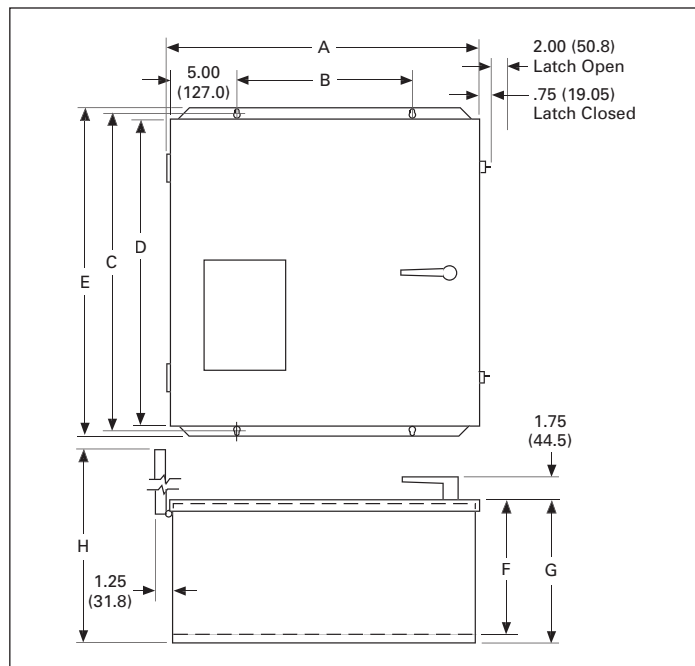


FIGURE 9. MANUAL AND MAINTENANCE BYPASS SWITCHES — DIMENSIONS IN INCHES (MM)

## Wall-Mount Transfer Switches Contactor, Molded Case and Circuit Breaker Design



Wall-Mount Transfer Switch

### Product Description

Eaton's Cutler-Hammer Wall-Mount Transfer Switches are designed for a variety of standby power applications for critical loads. They provide flexibility, reliability and value in a compact package. In the event of a primary power source interruption, a transfer switch provides an effective means to transfer the load circuits to an alternate power source while reducing the possibility of injury or property damage.

Wall-Mount Transfer Switches meet or exceed all industry standards for endurance, reliability and performance. They are listed under Underwriters Laboratories UL 1008 Standard for Transfer Switch Equipment and optionally available as suitable for emergency and standby systems as defined in NFPA 99 for health care facilities.

ATC-300 Automatic Transfer Switch shown above.

Combination Automatic Transfer Switches and Bypass Isolation are designed for applications where preventive maintenance, inspection and testing must be accomplished while maintaining continuity of power to the load. This is typically required in critical life support systems and standby power situations that require safe maintenance of the system with no disruption of the power.

### Electrical Ratings

- Molded case and circuit breaker 30 – 1000 amperes.
- 2-Position Contactors 100, 200, 320, 400 and 600 amperes.
- 3-Position Contactors 100, 200, 300, 400, 600, 800, 1000 and 1200 amperes.

#### Note:

For 3-position contactors, contact factory.

- 2-, 3- or 4-poles.
- Up to 600 Vac, 50/60 Hz.
- NEMA 1, 3R, 12, open.
- Suitable for emergency and standby systems (all loads).
- UL 1008 listed.
- CSA® C22.2 No. 178 certified.

### Industrial Design Highlights

- Double-throw, mechanically interlocked transfer mechanism.
- High withstand and closing ratings.
- Seismic Zone 4 qualified (BOCA®, CBC, IBC, UBC®).

### Standard Features

- Auxiliary relay contacts:
  - Source 1 present 2NO and 2NC
  - Source 2 present 2NO and 2NC
- Switch position indication contacts:
  - Source 1 position 1NO and 1NC
  - Source 2 position 1NO and 1NC
- Source 1 and Source 2 sensing:
  - Undervoltage/underfrequency
  - Overvoltage/overfrequency
  - 3-phase rotation protection
  - 3-phase voltage unbalance/loss
- Pre-transfer signal contacts 1NO/1NC.
- Go to Emergency (Source 2).
- Seven field-programmable time delays.
- LCD-based display for programming, system diagnostic and Help message display.
- Mimic diagram with source available and connected LED indication.
- Time-stamped history log.
- System test pushbutton.
- Programmable plant exerciser — OFF, daily, 7, 14, 28-day interval selectable run time 0 – 600 minutes no load/load with fail-safe.
- Safe manual operation under full load with permanently affixed operating handle.

#### Note:

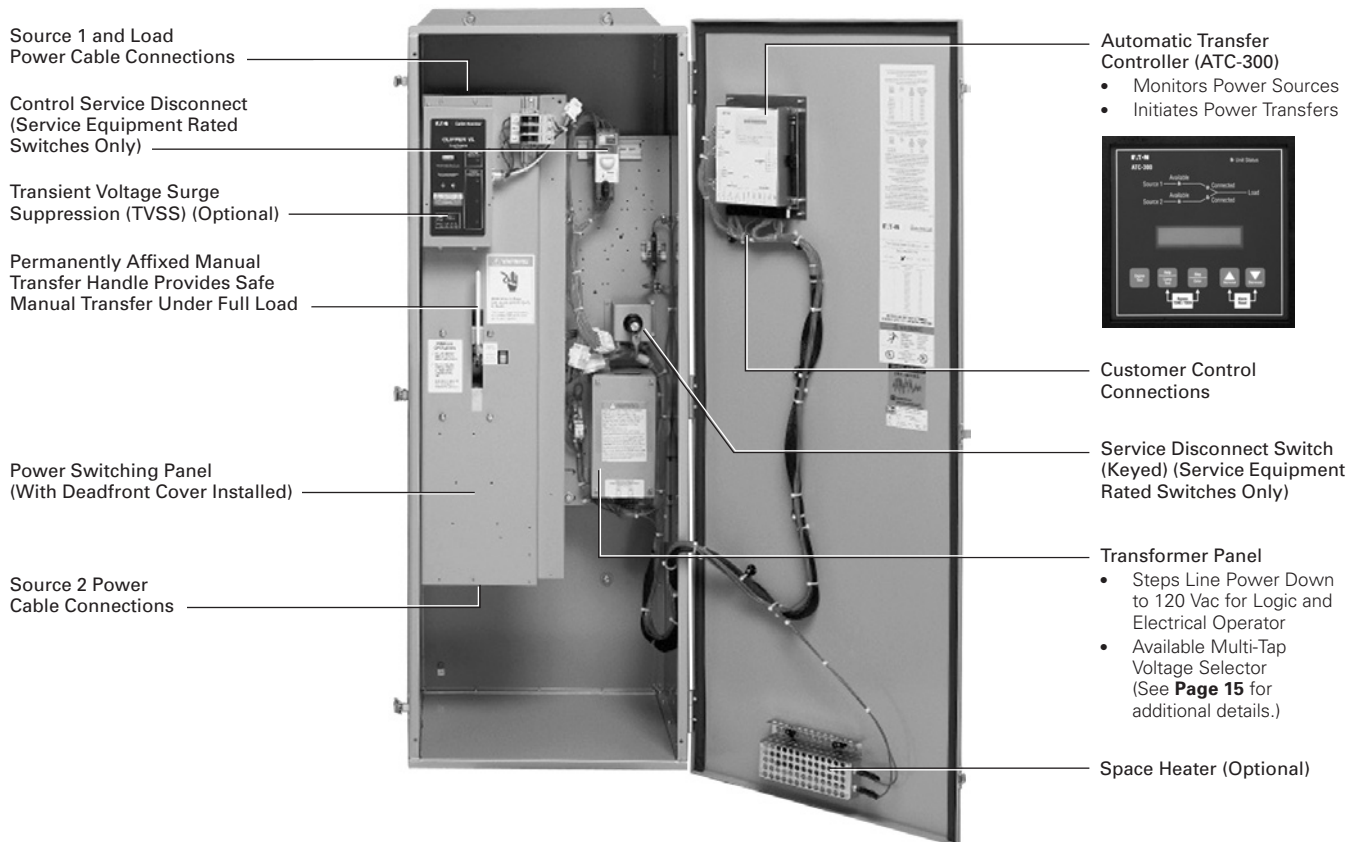
Not available on Contactor Transfer Switch.

### Optional Features

- Suitable for use as service equipment in the standard enclosure size. ①
- Available TVSS for power/controller, engine start circuit, phone and cable connections.
- Integrated distribution panels. ①
- Field-selectable multi-tap transformer panel permits operation on a wide range of system voltages.
- Integral overcurrent protection. ①
- Space heater with thermostat.
- Ammeter — load side.
- Stainless steel cover for controller.

① Not available on Contactor Transfer Switch.

## Basic Components of the Wall-Mount ATS



**Basic Components of Automatic Transfer Switches**

## Features, Benefits and Functions

### Cutler-Hammer Superior Design Transfer Switch Characteristics

#### Unmatched Performance and Versatility

The Cutler-Hammer family of wall-mount transfer switches offers unmatched performance, versatility and value for power switching applications. At the heart of these designs is the Cutler-Hammer Molded Case Switch, designed specifically to meet UL 1008.

#### Superior Main Contact Structure

All Cutler-Hammer Wall-Mount Transfer Switches meet or exceed the standards set forth in UL 1008 and UL 489. No other transfer switch manufacturer has met the rigid testing requirements of this combination of standards. Completely enclosed contacts add a measure of safety and reliability. It also ensures the integrity of the contact assemblies and minimizes the need for periodic maintenance of the contacts, reducing downtime.

#### Fast, Powerful and Safe Power Switching Mechanism

The power panel utilizes a unidirectional gear motor mechanism. The power panel can be operated manually under a FULL LOAD.

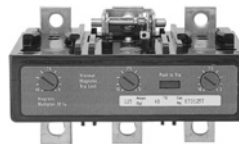
## Molded Case Switch Features



**Molded Case Switch**

- True 4-pole switched neutral availability.
- Totally enclosed contact assembly.

## Optional Integral Overcurrent Protection Capability



**Optional Thermal-Magnetic or Electronic Trip Units**

For service entrance and other applications, trip units can be integrated into the power switching section. This eliminates the need for separate upstream protective devices, saving cost and space.

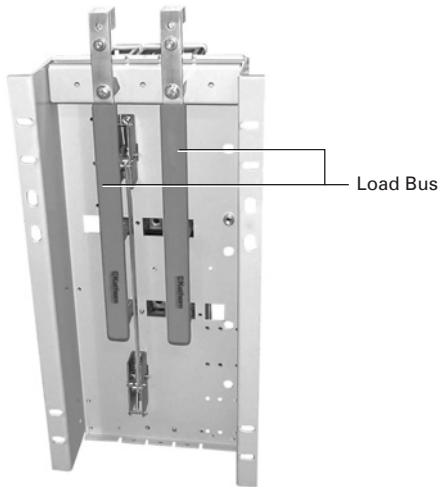
## Mechanical Interlock



**Triple Interlocks**

Wall-mount transfer switches feature a rear-mounted, patented fail-safe mechanical interlock to prevent paralleling of sources. This is, in addition to, software interlocking and the interlocking inherently provided by the transfer mechanism.

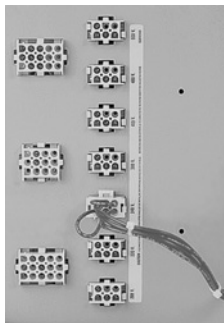
## Load Bus Assembly



**Load Bus**

The load bus can be oriented for either top or bottom access.

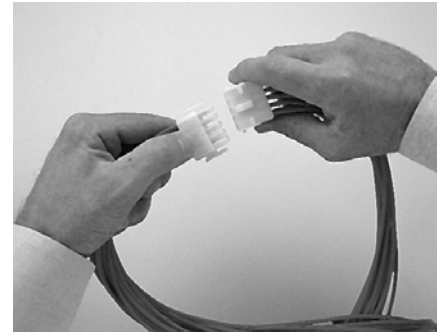
## Multi-Tap Voltage Selector



**Multi-Tap Voltage Selector**

The industry-exclusive Cutler-Hammer Multi-Tap System Voltage Selector allows our transfer switch to be applied on most system voltages just by proper insertion of the selector plug. Available in two configurations: Worldwide Multi-Tap with 600, 480, 415, 380, 240, 220 and 208 Vac, single- and 3-phase, 50 and 60 Hz taps. North American Multi-Tap with 600, 480, 240, 208 and 120 Vac, single- and 3-phase, 60 Hz taps.

## Ease of Maintenance



**Logic Disconnect Plugs**

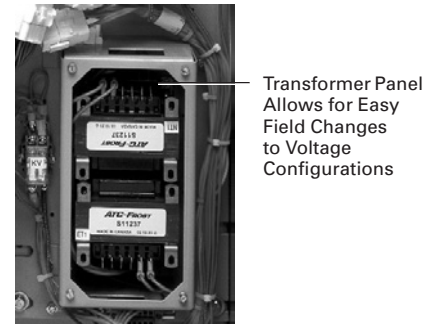
Keyed quick-disconnect plugs are provided for easy and complete isolation of the control circuitry.

Maintenance can be performed on the logic independent from the power sections and still allow the user to manually transfer power under full load conditions.

## North American Voltage Selector



**Transformer Panel Location**



**Transformer Panel Opened**

North American Multi-Tap transformer comes with 600, 480, 240, 208 and 120 Vac, single- and 3-phase, and 60 Hz taps which are all field selectable. Simply remove the steel cover and move the appropriate blue flag terminal to the desired voltage. All switches are shipped with the blue flag in the 600 volt position.

## Technical Data and Specifications

### Contactor-Based Transfer Switch ①

**TABLE 16. UL 1008 WITHSTAND AND CLOSE-ON RATINGS (KA)**

CONTACTOR STYLE	UL 1008 AMPERE RATING	SPECIFIC BREAKER RATING	
		MAXIMUM CIRCUIT BREAKER SIZE AMPERES	MAXIMUM AMPERES AT 480 VAC (UL)
61WNU-3FD	100	125	30,000
64WNU-3FD	200	250	50,000
64WNU-3FD	320	600	50,000
64WNU-3FD	400	600	50,000
66WNU-3FD	600	800	65,000

① Consult factory for withstand ratings on the 3-position contactor switches 100 – 1200 amperes.

**TABLE 17. TERMINAL DATA OPTIONS FOR POWER CABLE CONNECTIONS**

SWITCH RATING AMPERES	LINE SIDE (NORMAL AND STANDBY SOURCE)	LOAD CONNECTION	NEUTRAL CONNECTION
100	(1) #14 – 2/0	(1) #14 – 2/0	(3) #14 – 2/0
200	(1) #6 – 250	(1) #6 – 250	(3) 1/0 – 250
320	(1) #4/0 – 600	(1) #4/0 – 600	(6) 250 – 500
	(2) 1/0 – 250	(2) 1/0 – 250	(12) 4/0 – 500 (9) 500 – 750
400	(1) #4/0 – 600	(1) #4/0 – 600	(6) 250 – 500
	(2) 1/0 – 250	(2) 1/0 – 250	(12) 4/0 – 500 (9) 500 – 750
600	(2) #2 – 600	(2) #2 – 600	(12) 4/0 – 500 (9) 500 – 750

### Molded Case Transfer Switch and Circuit Breaker

**TABLE 18. UL 1008 WITHSTAND AND CLOSE-ON RATINGS (KA)**

SWITCH AMPERE RATING	UL 1008 3-CYCLE ANY BREAKER RATING			RATINGS WHEN USED WITH UPSTREAM FUSE		
	240 VAC	480 VAC	600 VAC	MAXIMUM FUSE RATING	FUSE TYPE	600 VAC
30 – 100	100	65	25	200	J, T	200
150	100	65	25	400	J, T	200
225	100	65	25	400	J, T	200
300	100	65	25	400	J, T	200
400	100	65	25	600	J, T	200
600 ②	100	65	25	1200	J, T	200
800 ②	65	50	25	1600	L	200
1000 ②	65	50	25	1600	L	200

② For 600, 800 and 1000 ampere ratings, 1- through 4-pole units are rated 35 kA.

**TABLE 19. WALL-MOUNT TRANSFER SWITCH STANDARD TERMINAL DATA FOR POWER CABLE CONNECTIONS**

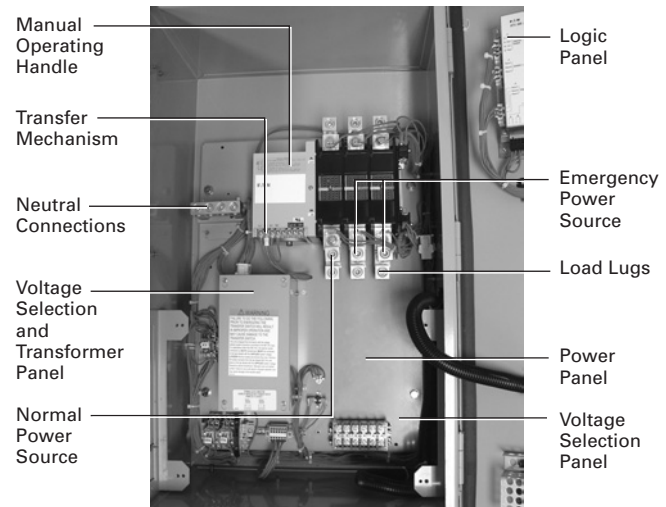
SWITCH AMPERE RATING	BREAKER FRAME	LINE SIDE (NORMAL AND STANDBY SOURCE)	LOAD CONNECTION	NEUTRAL CONNECTION
30 – 100	HFD	(1) #14 – 1/0	(1) #14 – 1/0	(3) #14 – 1/0
150 – 225	HFD	(1) #6 – 300	(1) #6 – 300	(3) #4 – 300
150 – 225	HKD	(1) #3 – 350	(1) #6 – 350	(3) #4 – 350
225 – 300	HKD	(1) #3 – 350	(1) #6 – 350	(3) #4 – 350
400	HLD	(1) 4/0 – 600	(2) #1 – 500	(6) 250 – 350
600	HLD	(1) 3/0 – 350	(2) #1 – 500	(6) 250 – 350
600	HMDL	(2) #1 – 500	(2) #1 – 500	(12) 4/0 – 500
600 (4-Pole)	NB	(3) 3/0 – 400	(3) 3/0 – 400	(3) 3/0 – 400
800	HMDL	(3) 3/0 – 400	(3) 3/0 – 400	(12) 4/0 – 500
800	HNB	(4) 4/0 – 500	(4) 4/0 – 500	(12) 4/0 – 500
1000	HNB	(4) 4/0 – 500	(4) 4/0 – 500	(12) 4/0 – 500

**Note:**

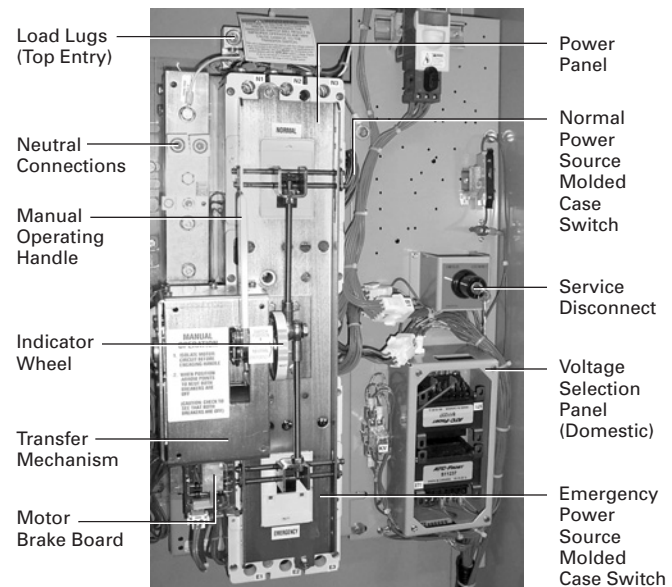
All terminals suitable for copper or aluminum conductors.

**Note:**

For alternate terminal sizes, contact Eaton.



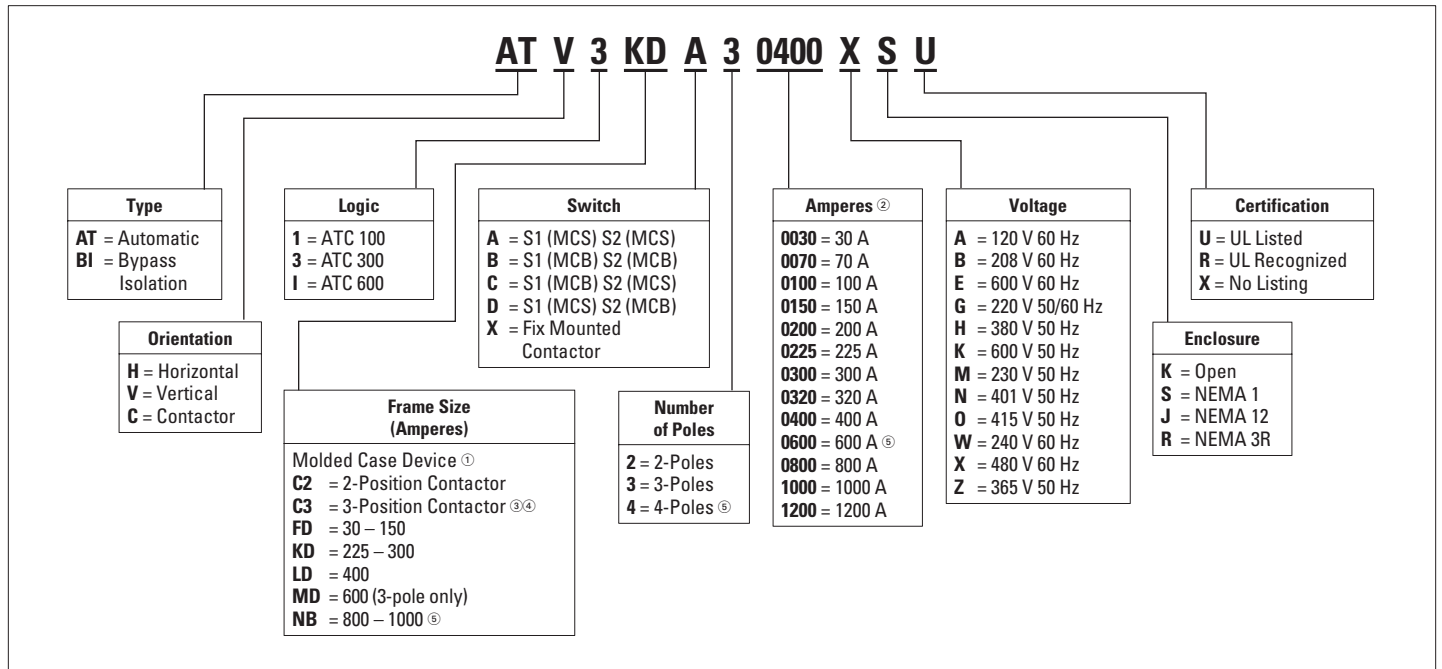
*Typical Contactor-Based ATS 100 – 600 Amperes*



*Typical (225 – 1000 Amperes) Vertical Design Transfer Switch Equipment*

## Product Selection

**TABLE 20. INDUSTRIAL MOLDED CASE TRANSFER SWITCH CATALOG NUMBERING SYSTEM**

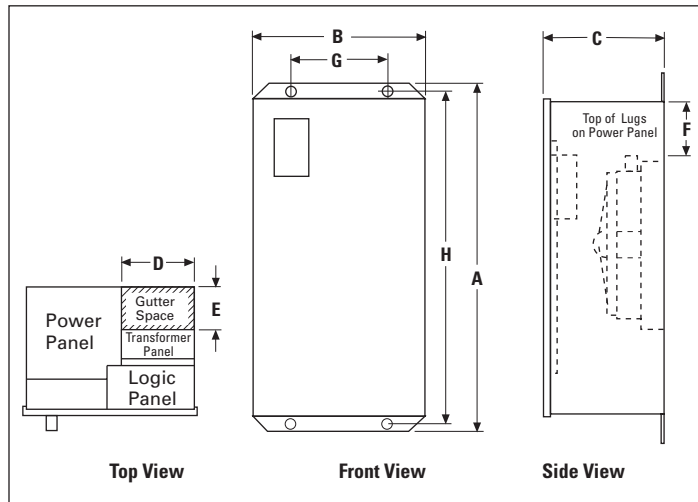


- ① HFD = 200 and 225 amperes, HLD = 600 amperes, HMD = 800 amperes for 240/120 Vac single-phase, 3-wire and 208Y/120 Vac 3-phase, 4-wire systems only.
- ② The Contactor-Based Transfer Switch is currently available in 100, 200, 320, 400 and 600 amperes only. Contact the factory for availability on the 800, 1000 and 1200 ampere switch.
- ③ For closed transition contactor, CTC8C3, consult factory.
- ④ For Bypass Isolation contactor, BICIC3, consult factory.
- ⑤ 4-pole 600 ampere will use an NB breaker.

**Note:**

MCB = Molded Case Breaker, MCS = Molded Case Switch.

### Layout Dimensions



**FIGURE 10. DIMENSION VIEWS**

See **Table 21** on **Page 18**.

Dimensions are approximate in inches (mm).  
Should not be used for construction purposes.

**TABLE 21. CONTACTOR-BASED AND MOLDED CASE TRANSFER SWITCHES — DIMENSIONS IN INCHES (MM) AND APPROXIMATE SHIPPING WEIGHTS IN LBS. (KG)**

SWITCH RATING AMPERES	SWITCH TYPE	ENCLOSURE			GUTTER SPACE		BOLT PATTERN		STANDARD TERMINALS ①			WEIGHT LBS. (KG)
		A HEIGHT	B WIDTH	C DEPTH	D WIDTH	E DEPTH	G HORIZONTAL	H VERTICAL	LINE SIDE (NORMAL LOAD & STANDBY SOURCE) CONNECTION	NEUTRAL CONNECTION		
<b>Contactor-Based — 2-Position ②</b>												
100	—	35.61 (904.5)	20.06 (509.5)	11.34 (288.0)	2.00 (51.0)	5.00 (127.0)	10.25 (260.4)	34.73 (882.1)	(1) #14 – 1/0	(1) #14 – 1/0	(3) #14 – 1/0	156 (71)
200	—	35.61 (904.5)	20.06 (509.5)	11.34 (288.0)	2.00 (51.0)	5.00 (127.0)	10.25 (260.4)	34.73 (882.1)	(1) #6 – 250 ③	(1) #6 – 250 ③	(3) 1/10 – 250	160 (73)
300	—	53.00 (1346.2)	25.81 (655.6)	16.72 (425.0)	4.00 (101.0)	12.00 (304.0)	16.00 (406.4)	50.48 (1282.2)	(1) #4/0 – 600 (2) 1/0 – 250	(1) #4/0 – 600 (2) 1/0 – 250	(3) 250 – 500 (12) 4/0 – 500 (9) 500 – 750	244 (110)
400	—	53.00 (1346.2)	25.81 (655.6)	16.72 (425.0)	4.00 (101.0)	12.00 (304.0)	16.00 (406.4)	50.48 (1282.2)	(1) #4/0 – 600 ③ (2) 1/0 – 250	(1) #4/0 – 600 ③ (2) 1/0 – 250	(3) 250 – 500 (12) 4/0 – 500 (9) 500 – 750	244 (110)
600	—	64.00 (1625.6)	25.81 (655.6)	16.72 (425.0)	3.00 (76.0)	9.00 (228.0)	16.00 (406.4)	61.48 (1561.6)	(2) #2 – 600 ③	(2) #2 – 600 ③	(12) 4/0 – 500 (9) 500 – 750	395 (180)
<b>Molded Case</b>												
30 – 100	HFD ③	47.74 (1213.0)	20.81 (528.6)	17.22 (437.0)	8.00 (203.2)	4.00 (101.6)	10.75 (273.0)	46.44 (1180.0)	—	—	—	232 (105)
150 – 225	HFD ③	47.74 (1213.0)	20.81 (528.6)	17.22 (437.0)	8.00 (203.2)	4.00 (101.6)	10.75 (273.0)	46.44 (1180.0)	—	—	—	232 (105)
30 – 100	HFD ④	47.74 (1213.0)	20.81 (528.6)	17.22 (437.0)	8.00 (203.2)	4.00 (101.6)	10.75 (273.0)	46.44 (1180.0)	—	—	—	240 (190)
150	HFD ④	47.74 (1213.0)	20.81 (528.6)	17.22 (437.0)	8.00 (203.2)	4.00 (101.6)	10.75 (273.0)	46.44 (1180.0)	—	—	—	240 (190)
150 – 225	HFD ③	35.61 (904.0)	20.06 (509.5)	13.34 (339.0)	8.00 (203.2)	4.00 (101.6)	10.75 (273.0)	34.31 (904.0)	—	—	—	150 (68)
150 – 225	HKD	56.00 (1422.4)	20.81 (528.6)	18.40 (467.4)	8.00 (203.2)	4.00 (101.6)	11.00 (279.4)	45.50 (1155.7)	—	—	—	305 (134)
300	HKD	53.00 (1346.2)	25.81 (655.6)	18.40 (467.4)	8.00 (203.2)	4.00 (101.6)	11.00 (279.4)	53.50 (1358.9)	—	—	—	295 (134)
400	HLD	53.00 (1346.0)	25.81 (655.6)	18.40 (467.4)	8.00 (203.2)	4.00 (101.6)	16.00 (406.4)	51.50 (1308.0)	—	—	—	425 (193)
600	HLD ③	64.00 (1625.6)	25.81 (655.6)	18.40 (467.4)	8.00 (203.2)	4.00 (101.6)	16.00 (406.4)	62.50 (1588.0)	—	—	—	475 (214)
600	HMDL	76.74 (1949.2)	25.81 (655.6)	19.50 (495.3)	8.00 (203.2)	4.00 (101.6)	16.00 (406.4)	75.15 (1908.8)	—	—	—	480 (218)
800	HMDL ③	76.74 (1949.2)	25.81 (655.6)	19.50 (495.3)	8.00 (203.2)	4.00 (101.6)	16.00 (406.4)	75.15 (1908.8)	—	—	—	510 (232)
800 – 1000	HNB	76.74 (1949.2)	25.81 (655.6)	19.50 (495.3)	8.00 (203.2)	4.00 (101.6)	16.00 (406.4)	75.15 (1908.8)	—	—	—	540 (245)

① Suitable with copper only.  
 ② For contactor-based 3-position dimensions, contact factory.  
 ③ 240/120 volt, single-phase, 3-wire or 208 volt, 3-phase, 4-wire systems only.  
 ④ With multi-tap voltage selection panel.

## Floor-Standing Magnum Transfer Switches



*Floor-Standing Magnum Transfer Switch*

### Product Description

Eaton's Magnum Transfer Switches are designed for a variety of standby power applications for critical and non-critical loads. They monitor both Source 1 (Normal) and Source 2 (Emergency) power sources. In the event of a Source 1 power interruption, these switches will automatically transfer the load circuits to the Source 2 power source. Once Source 1 power source has been restored, the process is automatically reversed.

The Magnum family of transfer switches covers applications ranging from 200 to 5000 amperes (A) through 600 Vac. Some of the applications are; automatic or non-automatic configurations, open or closed transition, and standard or rated suitable for use as service entrance. They are designed for applications where total system coordination must be accomplished while achieving a high level of Withstand, Interrupting, and Closing performance.

Drawout construction is available for applications, such as critical life support systems, where preventive maintenance, inspection, and testing must be accomplished while maintaining continuity of power to the load.

Eaton Magnum Transfer Switches meet or exceed all industry standards for endurance, reliability, and performance. They are listed under Underwriters Laboratories UL 1008 Standard for Transfer Switch Equipment. With certain options, they also comply with Source 2 and standby system requirements as defined in NFPA® 99 for health care facilities.

### Features, Benefits and Functions

- UL 1008 listed.
- Freestanding.
- Magnum insulated case devices.
- Fastest switching times available (<3 cycles).
- High withstand ratings.
- Full 60-cycle short time withstand capability.
- Safe manual transfer under load.
- Multi-tap voltage selection plug.
- Integral service entrance capability.
- Integral overcurrent protection capability.
- Drawout capability.
- Programmable microprocessor controller with keypad entry and display.
- Communications capable.
- Durable powder-coated steel enclosures.
- Seismic Zone 4 Qualified (BOCA, CBC, IBC, UBC).
- American Bureau of Shipping Qualified.
- ISO 9000.
- ISO 14000 Environmental.
- Ambient temperature range: -40°C to 40°C (-40°F to 104°F).
- Operating temperature range: -20°C to 70°C (-4°F to 158°F).
- Operating humidity: up to 90%.
- Relative humidity (non-condensing).

### Standards and Certifications

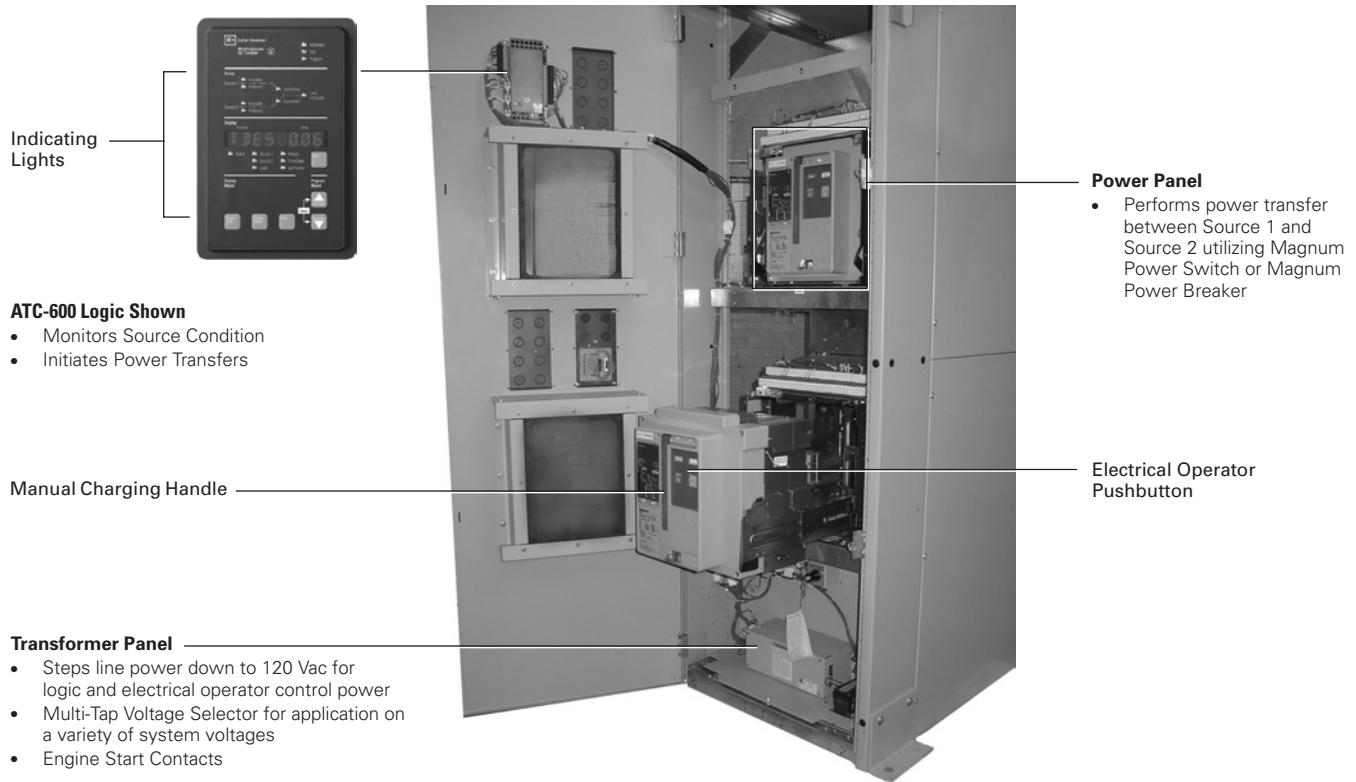
#### Magnum Transfer Switch Family

- Magnum fixed mount 200 – 5000 A.
- Magnum drawout 200 – 5000 A.

Eaton Magnum Transfer Switches offer the utmost in flexibility, reliability and value. These switches must exceed many national and international standards. They are designed and built in accordance with the following:

UL 891 . . . . .	Standard for Switchboards carrying up to 200,000 A
UL 1008 . . . . .	Standard for Safety for Automatic Transfer Switches 4000 and 5000 amperes available as UL 891 only.
UL 489 . . . . .	Standard for Circuit Breakers and Molded Case Switches
CSA 22.2-178 . . . . .	Canadian Transfer Switch Standard
NEC Articles . . . . .	Code Sections
517, 700, 701, 702 . . . . .	Applicable Switch Equipment
NFPA 110 . . . . .	Source 2 and Standby Power Systems
NFPA 99 . . . . .	Health Care Facilities
EGSA 100S . . . . .	Standard for Transfer Switches
NEMA ICS10 . . . . .	Standard for Transfer Switch Equipment
UBC . . . . .	Uniform Building Code for Seismic Zone 4
ISO® 9000 . . . . .	International Organization for Standardization
CBC . . . . .	California Building Code
IBC . . . . .	International Building Code
BOCA . . . . .	Building Officials Code Administrators.

## Basic Switch Components



*Basic Switch Components of Magnum Automatic Transfer Switches*

## Magnum Drawout Transfer Switch

### Magnum Drawout



**2000 Amperes, 3-Pole NEMA 1 Enclosed Drawout**

- 200 – 5000 amperes.
- 2-, 3-, 4-pole (except 4000 amperes: 2- and 3-pole only).
- 120 – 600 Vac.
- 100,000 amperes withstand/closing/interrupting at 480 Vac.
- Short Time Withstand – 85,000 for 30 cycles.
- Drawout construction with switch position indicator.
- Completely interchangeable power switching devices.
- Available in NEMA Type 1 and 3R enclosures.
- Rear, side and top cable access.

The Eaton Drawout Magnum Switch should be considered for any systems requiring either greater redundancy, easier maintainability, or where true selective coordination is desired.

The Eaton Drawout Magnum Switch provides the capability to isolate either of the two power sources (Source 1 or Source 2) and its associated logic, while maintaining power to the load.

Each switching section is independent and can be replaced either with a spare switch, or for less critical replacement needs, a replacement unit is available from the factory.

### Magnum Fixed Mount Transfer Switch

#### Magnum Fixed Mount



**2000 Amperes, 4-Pole, NEMA 1 Enclosed**

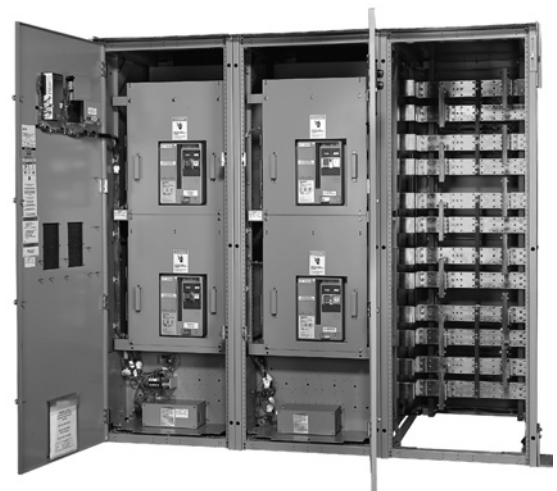
- 200 – 5000 A.
- 2-, 3-, 4-pole (except 3200 amperes: 2- and 3-pole only).
- 120 – 600 Vac.
- 100,000 amperes withstand/closing/interrupting at 480 Vac.
- Short Time Withstand – 85,000 for 30 cycles.
- Fixed mount construction.
- Available in NEMA Type 1 and 3R enclosures.
- Rear, side and top cable access.

### Transfer Switch Withstand Ratings

**TABLE 22. SYSTEMS COORDINATION INFORMATION — WITHSTAND, CLOSING AND INTERRUPTING RATINGS**

RATING WHEN USED WITH UPSTREAM CIRCUIT BREAKER		RATING WHEN USED WITH UPSTREAM FUSE
TRANSFER SWITCH AMPERE RATING	3 CYCLE 600 V (KA)	30 CYCLE 600 V (KA)
800	100	85
1000	100	85
1200	100	85
1600	100	85
2000	100	85
2500	100	85
3200	100	85
4000	100	85
5000	100	85

Tested in accordance with UL 1008. Eaton Drawout Magnum Transfer Switch will coordinate with a power switching device short time rating. Contact factory for details.



**Front Access Option 54A is Available on All Magnum Designs**

## Power and Transformer Panels

### Unmatched Performance and Versatility

The Eaton family of Magnum transfer switches offers unmatched performance, versatility, and value for standby power applications. At the heart of these designs is the Magnum switch with the following features:

#### Superior Main Contact Structure

All Eaton Magnum Transfer Switches meet or exceed the standards set forth in UL 1008 and UL 489 with high withstand, totally enclosed Magnum switches. No other transfer switch manufacturer has met the rigid testing requirements of this combination of standards. Completely enclosed contacts add a measure of safety and reliability. It also ensures the integrity of the contact assemblies and minimizes the need for periodic maintenance of the contacts, reducing downtime and maintenance time.

#### Fast, Powerful and Safe Switching Mechanism

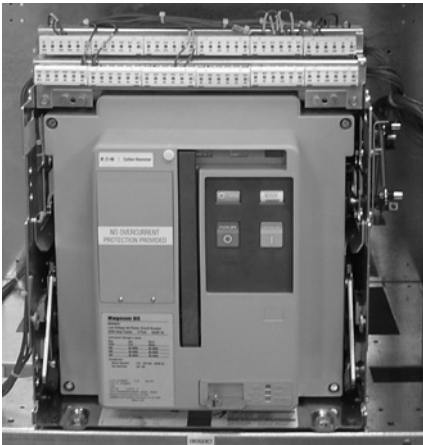
The mechanism utilizes a high speed  $\leq$  than 3-cycle stored energy switching mechanism. This mechanism can be operated manually under a FULL LOAD.

#### Ease of Coordination and Application — Short Time Withstand

The use of electronic trips has allowed performance curve shaping to facilitate proper system coordination. The most significant is the "short time" rated trip unit.

These trip settings may be set for what are considered extremely high currents for much longer durations than the 3-cycle withstand test required under UL 1008. To facilitate improved coordination, Eaton Magnum transfer switches have been tested and are provided with 30-cycle, extended withstand ratings.

### Magnum Switch Features



**Magnum Insulated Case Switch**

- UL 489 and UL 1008 listed. 4000 and 5000 amperes available as UL 891 only.
- 65 – 100 kA standard withstand ratings.
- 30-cycle, extended withstand ratings.
- $\leq$  than 3-cycle closing speed.
- Electrically operated.
- True 4-pole switched neutral availability.
- Totally enclosed contact assembly.
- 3A/3B auxiliary contacts for customer connection (each Magnum switch).

## Optional Integral Overcurrent Protection Capability

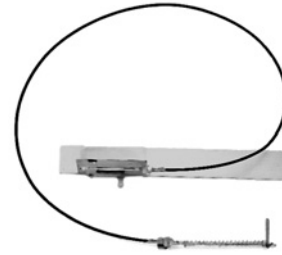


**Optional Digitrip™ Magnum Trip Unit**

### Service Entrance

For service entrance and other applications, Digitrip solid-state trip units can be integrated into the power switching section. This eliminates the need for separate upstream protective devices, saving cost and space. Available with various combinations of Long, Short Time, Instantaneous, Ground Fault Protection, and Communications.

### Interlocking for Open Transition Applications



**Mechanical Cable Interlock**

The open transition type Magnum Transfer Switches feature both mechanical (cable) and electrical interlocking to prevent paralleling of sources.

### Multi-Tap Voltage Selector

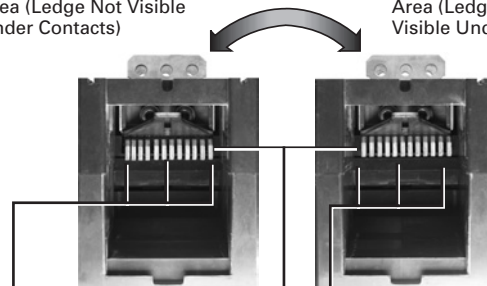


**Voltage Selection Terminals**

Allows the transfer switch to be readily applied on most system voltages worldwide by connecting to the proper terminals. Available system voltages include 120, 208, 220, 230, 240, 380, 401, 415, 480 or 600 Vac, 50 or 60 Hz.

Contact Wear Inspection Area (Ledge Not Visible Under Contacts)

Contact Wear Inspection Area (Ledge Now Becoming Visible Under Contacts)



**Side-to-Side Ledge**

Contact Wear Indicator — Contacts Closed and in Good Condition

Contact Wear Indicator — Contacts Closed and Wear is Indicated

**Contact Wear Indicators**

## Logic

### Application Versatility

Whether the application calls for open or closed transition, Eaton has the right logic controller for the task. IQ Transfer controllers have set a new standard for transfer switch technology featuring:

- Microprocessor-based logic.
- Digital display.
- Field set point programmability.
- Transfer history.
- PowerNet™ Communications capability.
- Voltmeter and frequency meter.
- True rms voltage sensing.
- Mimic BUS/LED display.
- Load voltage decay delayed transition capability.
- In-phase monitor capability.
- Field upgrade capability.

### Automatic Transfer Open Transition



**ATC-600 IQ Transfer**

Open transition type Magnum transfer switches utilize the Eaton programmable ATC-600 microprocessor-based logic controller.

Refer to technical data TD.15A.05.T.E Open Transition IQ Transfer (ATC-600) for Automatic Transfer Switches for additional information.

### Automatic Transfer Closed Transition

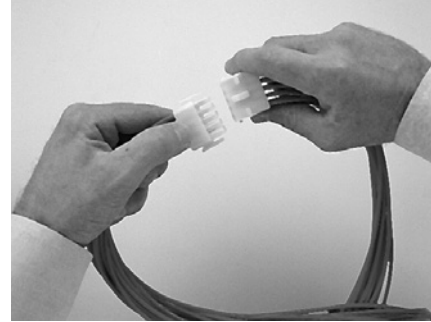


**ATC-800 Closed Transition IQ Transfer**

Closed transition applications feature the ATC-800 Closed Transition IQ Transfer logic controller.

Refer to technical data TD.15A.09.T.E Closed Transition IQ Transfer (ATC-800) for Automatic Transfer Switches for additional information.

### Ease of Maintenance



**Logic Disconnect Plugs**

Keyed quick-disconnect plugs are provided for easy and complete isolation of the control circuitry.

Maintenance can be performed on the logic independent from the power sections and still allow the user to manually transfer power under full load conditions.

## Bypass Isolation Transfer Switch



*Bypass Isolation Transfer Switch*

### Product Description

A bypass isolation switch utilizes loadbreak isolation and bypass transfer power contacts. Thus, should voltage be lost on the line to which the ATS is connected, and should a manual bypass be required to the other line, this can be accomplished safely and quickly as described below. With contactor designs utilizing non-loadbreak isolation and bypass switches, manual bypass to the other line is hindered by mechanical or electrical safety interlocking.

### Application Description

The bypass isolation switch is designed for applications where maintenance, inspection and testing must be performed while maintaining continuous power to the load. This is typically required in critical life support systems and standby power situations calling for safe system maintenance with no power disruptions. Such a design allows for the quick removal of the different switching devices for inspection, maintenance or replacement.

### Features, Benefits and Functions

The Eaton transfer switch is a rugged, compact design utilizing Magnum power switches or Magnum power circuit breakers to transfer essential loads from one power source to another. Open transition switching devices are interlocked to prevent both switching devices from being closed at the same time. The versatile design, in addition to standard transfer functions, offers an optional integral thermal and short circuit protection in either or both switching devices.

The switching devices are in a compact vertical arrangement. The logic can be easily disconnected from the switching device without disturbing critical connections. The enclosure is free standing, and, by using the specially supplied cleats, the switch is seismic approved (Option 42). The terminals are mounted in the rear of the switch, permitting rear, top, bottom or side cable or bus bar entrance.

The switching devices have a high withstand rating. The high-speed, stored-energy switching mechanism guarantees a transfer time of less than 3 cycles.

### Features

- Reliable microprocessor logic.
- Designed to safely withstand fault currents.
- Eliminates need for complex interlocks.
- Most versatile bypass isolation transfer switch available.
- Cutler-Hammer drawout cassette design.
- Overcurrent protection available.
- No loadbreak when bypassing to the same source.
- Drawout capabilities on both ATS and Bypass portions.
- Compact design.
- Ability to test power switching elements during drawout process.
- Power switching devices completely interchangeable between ATS and Bypass portions.

### Standards and Certifications

Eaton transfer switch equipment is listed for application by UL and CSA. In addition, Eaton ATSs are listed in File E38116 by Underwriters Laboratories under Standard UL 1008. This standard covers requirements for ATSs intended for use in ordinary locations to provide for lighting and power as follows:

- A. In emergency systems, in accordance with Articles 517 and 700 in the National Electrical Code (NEC), American National Standards Institute/National Fire Protection Association (ANSI/NFPA) 70 and the NFPA No. 76A and/or
- B. In standby systems, in accordance with Article 702 of the NEC and/or
- C. In legally required standby systems in accordance with Article 701 of the NEC. Eaton ATSs are available to meet NFPA 110 for emergency and standby power systems, and NFPA 99 for health care facilities when ordered with the appropriate options. Since Eaton ATSs utilize specially designed switches and/or switching devices as the main power switching contacts, these devices must also be listed under the additional UL Standard 1066. UL utilizes two basic types of listing programs:
  - a. Label Service and b) Re-examination. UL 1066 employs a label service listing program which requires an extensive follow-up testing program for listed devices. Standard UL 1008 for ATSs lists devices under the re-examination program which only requires a continual physical re-examination of the components used in the product to ensure consistency with the originally submitted device. Follow-up testing IS NOT required by UL 1008. Representative production samples of switches and switching devices used in Eaton ATSs are subjected to a complete test program identical to the originally submitted devices on an ongoing periodic basis per UL 1066. The frequency of such a re-submittal can be as often as every quarter for a low ampere device.

#### Note:

IBC seismic qualified.

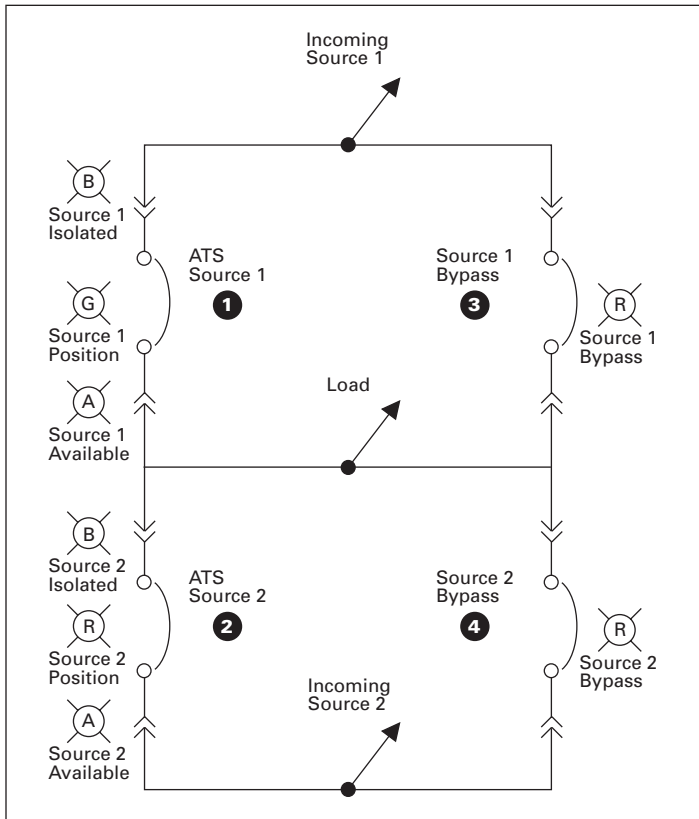
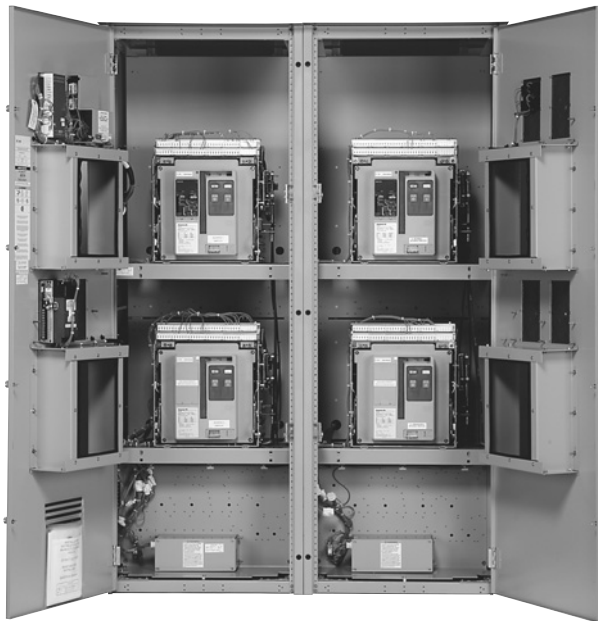


FIGURE 11. TYPICAL BYPASS ISOLATION SWITCH SCHEMATIC

TRANSFER SWITCH AMPERE RATING	RATING WHEN USED WITH UPSTREAM CIRCUIT BREAKER	
	3-CYCLE 600 VOLT (KA)	30-CYCLE 600 VOLT (KA)
200	100	85
1000	100	85
1200	100	85
1600	100	85
2000	100	85
2500	100	85
3200	100	85
4000	100	85
5000	100	85

- Tested in accordance with UL 1008.
- Eaton Drawout Magnum Transfer Switch will coordinate with a power switching device short time rating.
- Contact factory for details.



Magnum Bypass Isolation Front View

## Product Selection

Eaton Transfer Switch Equipment offers flexibility and versatility to the system designer and user. All switches include the basic features necessary for normal operation as standard. Eaton also offers an extensive array of optional features/accessories that allows the user to customize a new transfer switch to match the application. Select the appropriate catalog number for the application from **Table 24** below. Then choose from **Table 44** any optional features/accessories needed to complete the project requirements.

## Catalog Number: ATVIMGB33200XRU with Optional Features 16B, 37B and 42.

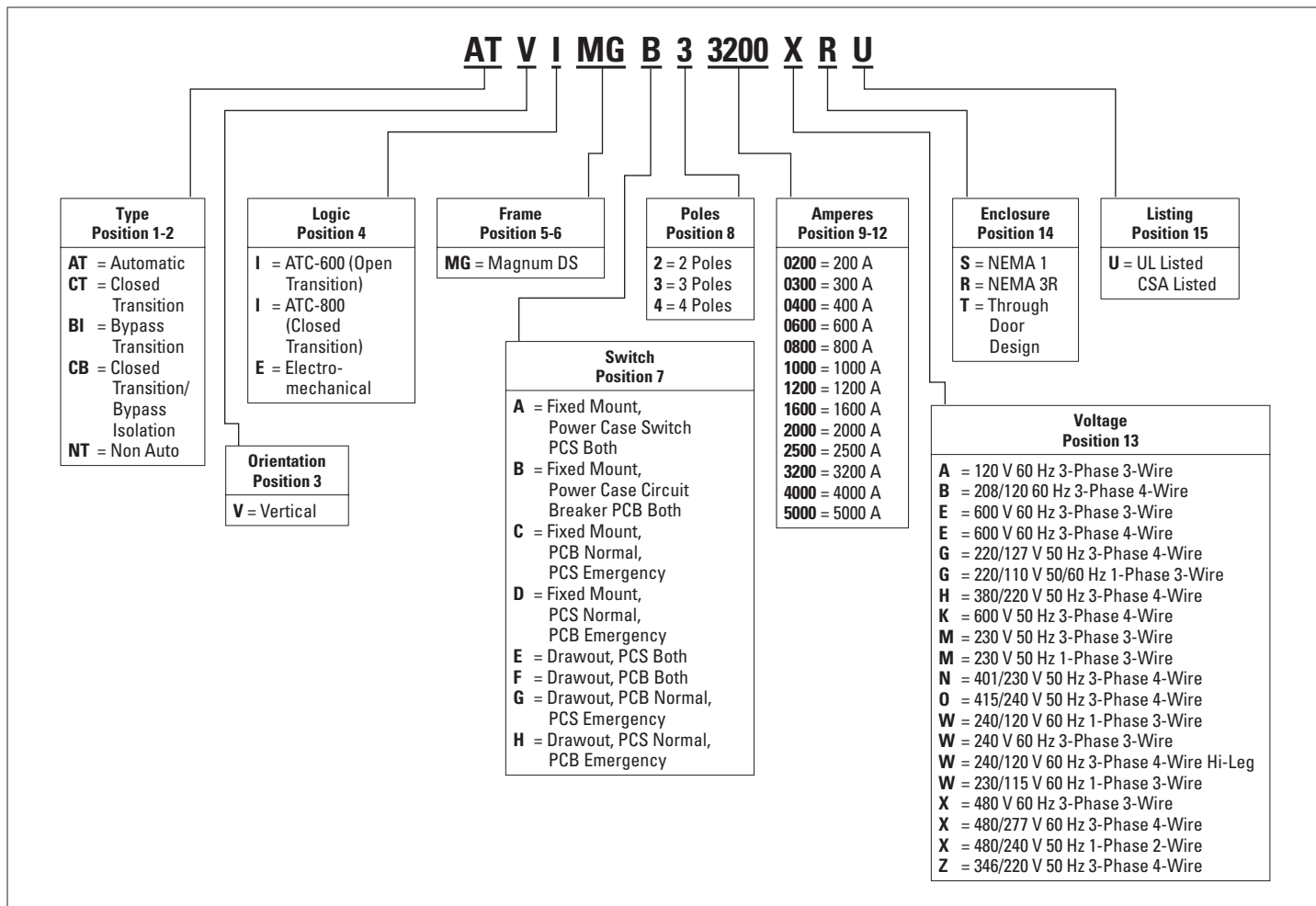
The example above would specify the following:

- Automatic transfer switch.
- Vertical configuration.
- IQ transfer logic.
- Magnum DS frame.
- Fixed mount.
- 3-pole.
- 3200 amperes.
- 480 volts.
- NEMA 1 enclosure.
- UL listed.
- ATC-600 Transfer Logic.
- Integral overcurrent protection both sources.
- Service entrance rated with ground fault protection.
- Seismic Zone 4 qualified.

## Catalog Numbering System

**TABLE 24. CATALOG NUMBERING SYSTEM — MAGNUM BYPASS, AUTOMATIC AND NON-AUTOMATIC TRANSFER SWITCHES 200 – 5000 AMPERES**

Using the Catalog Numbering System provides an overview of the ten basic style/feature categories which generate the 15 digit catalog number.



PCS = Power Case Switch  
PCB = Power Circuit Breaker

## Dimensions and Weights — Magnum Fixed Mount and Drawout Transfer Switches

### Automatic, Non-Automatic and Manual Transfer Switches

Enclosures meet all current applicable NEMA and UL standards for conduit entry, cable bending, gutter space, and shielding of live components.

### NEMA 1 and NEMA 3R Enclosures

Magnum Transfer Switches are supplied with a front door only. They can be mounted in a corner or against a wall. Access to cable space can be via either side, bottom, top, or the rear.

#### Note:

Add 3 inches to the height, 6 inches to the width, and 3 inches to the depth to all enclosure dimensions to account for the seismic Zone 4 mounting brackets.

**TABLE 25. MAGNUM FIXED MOUNTED TRANSFER SWITCHES — DIMENSIONS ① IN INCHES (MM)**

AMPERE RATING	NUMBER OF POLES	A HEIGHT	B WIDTH	C DEPTH	SHIPPING WEIGHT LBS. (KG)
<b>NEMA 1 Enclosed Fixed Mount Transfer Switch</b>					
200 – 2000	2	90.00 (2286)	32.00 (813)	48.00 (1219)	1050 (477)
200 – 2000	3	90.00 (2286)	32.00 (813)	48.00 (1219)	1050 (477)
200 – 2000	4	90.00 (2286)	32.00 (813)	48.00 (1219)	1250 (568)
2500 – 3200	2	90.00 (2286)	44.00 (1118)	48.00 (1219)	1900 (863)
2500 – 3200	3	90.00 (2286)	44.00 (1118)	48.00 (1219)	1900 (863)
2500 – 3200	4	90.00 (2286)	44.00 (1118)	48.00 (1219)	2000 (910)
4000	2 or 3	91.50 (2324)	48.00 (1219)	48.00 (1219)	1150 (521)
4000	4	91.50 (2324)	54.00 (1372)	48.00 (1219)	1300 (589)
5000	2 or 3	91.50 (2324)	48.00 (1219)	48.00 (1219)	1300 (589)
5000	4	91.50 (2324)	54.00 (1372)	48.00 (1219)	1450 (657)
<b>NEMA 3R Enclosed Fixed Mounted Transfer Switch</b>					
200 – 2000	2	90.00 (2286)	32.00 (711)	63.00 (1600)	1600 (726)
200 – 2000	3	90.00 (2286)	32.00 (711)	63.00 (1600)	1600 (726)
200 – 2000	4	90.00 (2286)	32.00 (711)	63.00 (1600)	1800 (817)
2500 – 3200	2	90.00 (2286)	44.00 (1118)	63.00 (1600)	2400 (1090)
2500 – 3200	3	90.00 (2286)	44.00 (1118)	63.00 (1600)	2400 (1090)
2500 – 3200	4	90.00 (2286)	44.00 (1118)	63.00 (1600)	2500 (1135)
4000	2 or 3	—	—	—	—
4000	4	—	—	—	—
5000	2 or 3	—	—	—	—
5000	4	—	—	—	—

① A wireway is required, See Table 27.

Dimensions are approximate in inches (mm).  
Should not be used for construction purposes.

**TABLE 26. WIREWAY DIMENSIONS — DIMENSIONS IN INCHES (MM)**

AMPERE RATING	NUMBER OF POLES	A HEIGHT	B WIDTH	C DEPTH	SHIPPING WEIGHT LBS. (KG)
3200 & Below	All	91.00 (2311)	32.00 (813)	48.00 (1219)	850 (386)
4000	3	91.50 (2324)	38.00 (965)	48.00 (1219)	900 (408)
4000	4	91.50 (2324)	38.00 (965)	48.00 (1219)	1050 (476)
5000	3	91.50 (2324)	38.00 (965)	60.00 (1524)	1100 (498)
5000	4	91.50 (2324)	38.00 (965)	60.00 (1524)	1250 (566)

#### Note:

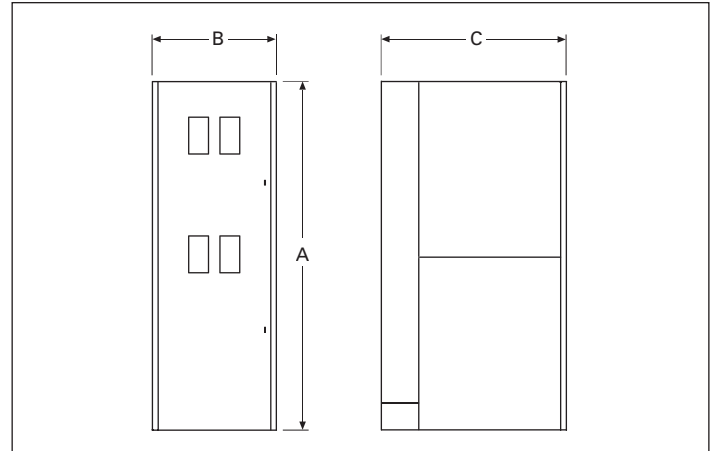
All weights are approximate.

**TABLE 27. CONNECTION TYPE**

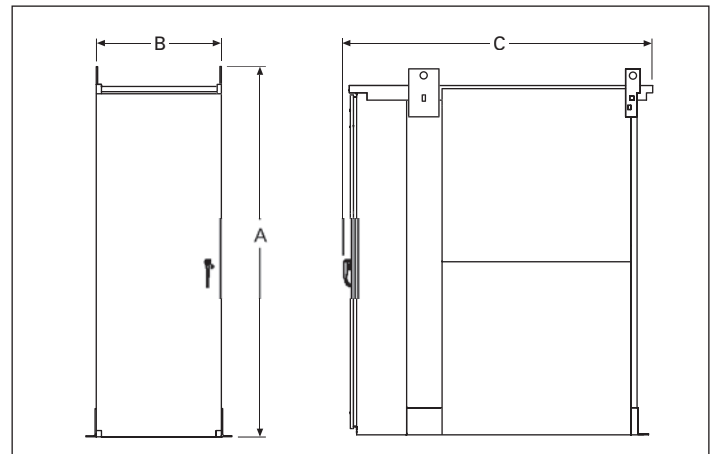
CONNECTION TYPE			
LINE	EMERGENCY	LOAD	WIREWAY
Cable	Cable	Cable	Yes
Bus	Cable	Cable	Yes
Cable	Bus	Cable	Yes
Cable	Cable	Bus	Yes
Bus	Bus	Cable	No
Bus	Cable	Bus	No
Cable	Bus	Bus	No
Bus	Bus	Bus	No

#### Note:

A wireway is required in accordance with Table 27.



**Figure 12. 200 – 2000 Ampere Fixed Mount NEMA 1**



**FIGURE 13. 200 – 2000 Ampere Fixed Mount NEMA 3R**

**TABLE 28. MAGNUM DRAWOUT TRANSFER SWITCHES — DIMENSIONS ① IN INCHES (MM)**

AMPERE RATING	NUMBER OF POLES	A HEIGHT	B WIDTH	C DEPTH	SHIPPING WEIGHT LBS. (KG)
<b>NEMA 1 Enclosed Drawout Transfer Switch</b>					
200 – 2000	2	90.00 (2286)	32.00 (813)	60.00 (1524)	1600 (727)
200 – 2000	3	90.00 (2286)	32.00 (813)	60.00 (1524)	1600 (727)
200 – 2000	4	90.00 (2286)	32.00 (813)	60.00 (1524)	1900 (864)
2500 – 3200	2	90.00 (2286)	44.00 (1118)	60.00 (1524)	2500 (1136)
2500 – 3200	3	90.00 (2286)	44.00 (1118)	60.00 (1524)	2500 (1136)
2500 – 3200	4	90.00 (2286)	44.00 (1118)	60.00 (1524)	2800 (1273)
4000	2 or 3	91.50 (2324)	48.00 (1219)	60.00 (1524)	1250 (566)
4000	4	91.50 (2324)	54.00 (1372)	60.00 (1524)	1400 (635)
5000	2 or 3	91.50 (2324)	48.00 (1219)	60.00 (1524)	1400 (635)
5000	4	91.50 (2324)	54.00 (1372)	60.00 (1524)	1550 (703)
<b>NEMA 3R Enclosed Drawout Transfer Switch</b>					
200 – 2000	2	90.00 (2286)	32.00 (813)	75.00 (1905)	2100 (953)
200 – 2000	3	90.00 (2286)	32.00 (813)	75.00 (1905)	2100 (953)
200 – 2000	4	90.00 (2286)	32.00 (813)	75.00 (1905)	2400 (1090)
2500 – 3200	2	90.00 (2286)	44.00 (1118)	75.00 (1905)	3000 (1362)
2500 – 3200	3	90.00 (2286)	44.00 (1118)	75.00 (1905)	3000 (1362)
2500 – 3200	4	90.00 (2286)	44.00 (1118)	75.00 (1905)	3300 (1498)
4000	2 or 3	—	—	—	—
4000	4	—	—	—	—
5000	2 or 3	—	—	—	—
5000	4	—	—	—	—

① A wireway is required, See Table 30.

**TABLE 29. WIREWAY DIMENSIONS — DIMENSIONS IN INCHES (MM)**

AMPERE RATING	NUMBER OF POLES	A HEIGHT	B WIDTH	C DEPTH	SHIPPING WEIGHT LBS. (KG)
3200 & Below	All	91.00 (2311)	32.00 (813)	48.00 (1219)	850 (386)
4000	3	91.50 (2324)	38.00 (965)	48.00 (1219)	900 (408)
4000	4	91.50 (2324)	38.00 (965)	48.00 (1219)	1050 (476)
5000	3	91.50 (2324)	38.00 (965)	60.00 (1524)	1100 (498)
5000	4	91.50 (2324)	38.00 (965)	60.00 (1524)	1250 (566)

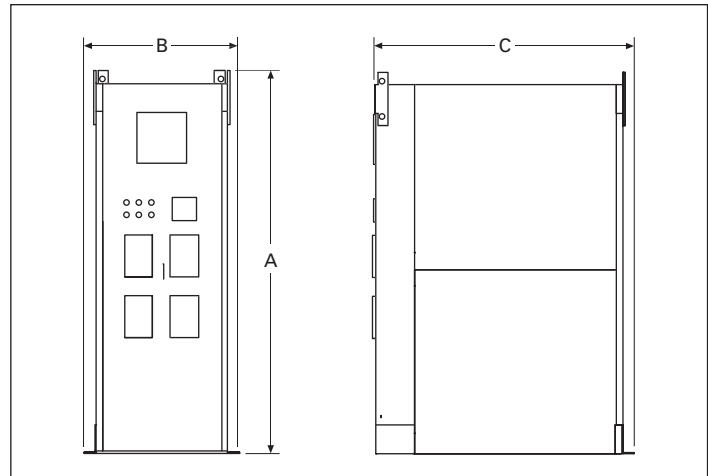
**Note:**  
All weights are approximate.

Dimensions are approximate in inches (mm).  
Should not be used for construction purposes.

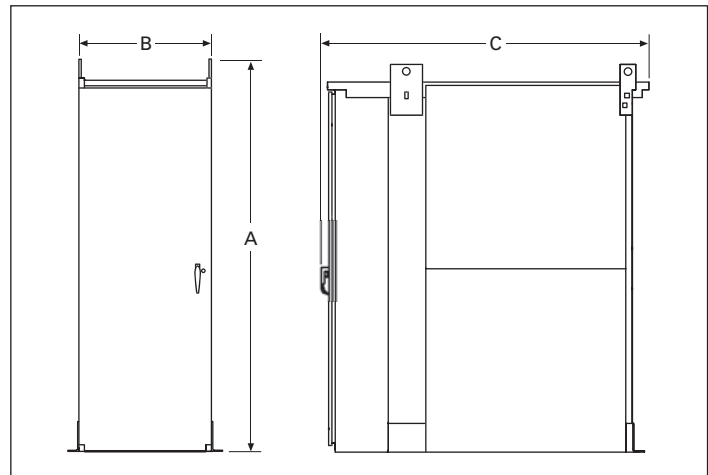
**TABLE 30. CONNECTION TYPE**

CONNECTION TYPE			
LINE	EMERGENCY	LOAD	WIREWAY
Cable	Cable	Cable	Yes
Bus	Cable	Cable	Yes
Cable	Bus	Cable	Yes
Cable	Cable	Bus	Yes
Bus	Bus	Cable	No
Bus	Cable	Bus	No
Cable	Bus	Bus	No
Bus	Bus	Bus	No

**Note:**  
A wireway is required in accordance with Table 30.



**FIGURE 14. 200 – 2000 AMPERE DRAWOUT NEMA 1**



**FIGURE 15. 200 – 2000 AMPERE DRAWOUT NEMA 3R**

**TABLE 31. MAGNUM BYPASS ISOLATION DRAWOUT TRANSFER SWITCHES — DIMENSIONS ① IN INCHES (MM)**

AMPERE RATING	NUMBER OF POLES	A HEIGHT	B WIDTH	C DEPTH	SHIPPING WEIGHT LBS. (KG)
<b>NEMA 1 Enclosed Drawout Transfer Switch</b>					
200 – 2000	2	90.00 (2286)	64.00 (1626)	60.00 (1524)	3100 (1409)
200 – 2000	3	90.00 (2286)	64.00 (1626)	60.00 (1524)	3100 (1409)
200 – 2000	4	90.00 (2286)	64.00 (1626)	60.00 (1524)	3700 (1682)
2500 – 3200	2	90.00 (2286)	64.00 (1626)	60.00 (1524)	4700 (2136)
2500 – 3200	3	90.00 (2286)	64.00 (1626)	60.00 (1524)	4700 (2136)
2500 – 3200	4	90.00 (2286)	64.00 (1626)	60.00 (1524)	5500 (2500)
4000	2 or 3	91.50 (2324)	48.00 (1219)	60.00 (1524)	1250 (568)
4000	4	91.50 (2324)	54.00 (1372)	60.00 (1524)	1400 (635)
5000	2 or 3	91.50 (2324)	48.00 (1219)	60.00 (1524)	1400 (635)
5000	4	91.50 (2324)	54.00 (1372)	60.00 (1524)	1550 (703)
<b>NEMA 3R Enclosed Drawout Transfer Switch</b>					
200 – 2000	2	90.00 (2286)	64.00 (1626)	75.00 (1905)	3700 (1682)
200 – 2000	3	90.00 (2286)	64.00 (1626)	75.00 (1905)	3700 (1682)
200 – 2000	4	90.00 (2286)	64.00 (1626)	75.00 (1905)	4300 (1955)
2500 – 3200	2	90.00 (2286)	64.00 (1626)	75.00 (1905)	5300 (2410)
2500 – 3200	3	90.00 (2286)	64.00 (1626)	75.00 (1905)	5300 (2410)
2500 – 3200	4	90.00 (2286)	64.00 (1626)	75.00 (1905)	6000 (2730)
4000	2 or 3	—	—	—	—
4000	4	—	—	—	—
5000	2 or 3	—	—	—	—
5000	4	—	—	—	—

① A wireway is required, See Table 33.

**TABLE 32. WIREWAY DIMENSIONS — DIMENSIONS IN INCHES (MM)**

AMPERE RATING	NUMBER OF POLES	A HEIGHT	B WIDTH	C DEPTH	SHIPPING WEIGHT LBS. (KG)
3200 & Below	All	91.00 (2311)	32.00 (813)	48.00 (1219)	850 (386)
4000	3	91.50 (2324)	38.00 (965)	48.00 (1219)	900 (408)
4000	4	91.50 (2324)	38.00 (965)	48.00 (1219)	1050 (476)
5000	3	91.50 (2324)	38.00 (965)	60.00 (1524)	1100 (498)
5000	4	91.50 (2324)	38.00 (965)	60.00 (1524)	1250 (566)

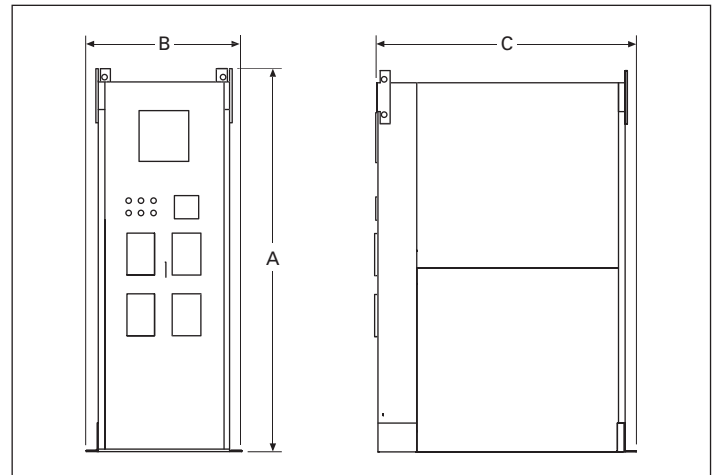
**Note:**  
All weights are approximate.

Dimensions are approximate in inches (mm).  
Should not be used for construction purposes.

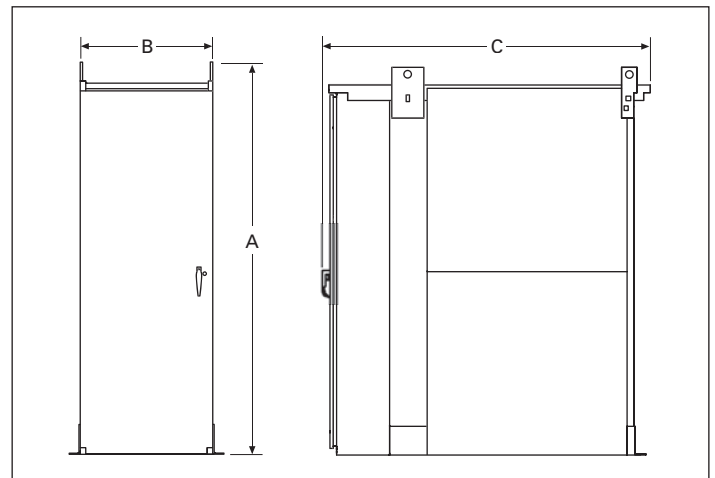
**TABLE 33. CONNECTION TYPE**

CONNECTION TYPE			
LINE	EMERGENCY	LOAD	WIREWAY
Cable	Cable	Cable	Yes
Bus	Cable	Cable	Yes
Cable	Bus	Cable	Yes
Cable	Cable	Bus	Yes
Bus	Bus	Cable	No
Bus	Cable	Bus	No
Cable	Bus	Bus	No
Bus	Bus	Bus	No

**Note:**  
A wireway is required in accordance with Table 33.

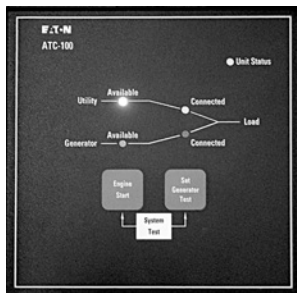


**FIGURE 16. 200 – 2000 AMPERE DRAWOUT MOUNT NEMA 1**



**FIGURE 17. 200 – 2000 AMPERE DRAW-OUT MOUNT NEMA 3R**

## ATC-100 Controller



ATC-100 Controller

### Product Description

The ATC-100 Controller is a comprehensive, multi-function, microprocessor-based ATS controller. It is a compact, self-contained, panel mounted device designed to replace traditional relay and solid-state logic panels.

### Application Description

The ATC-100 Controller provides an unmatched degree of programmed flexibility to address the needs of any system. It operates from all system voltages between 120 and 480 Vac, single-phase and 3-phase, at 50 or 60 Hz. In addition, a period of no control power operation is provided. The ATC-100 Controller monitors the condition of the 3-phase line-to-line voltage and frequency of both the Utility and Generator power sources. It can also be set up for single-phase operation. The ATC-100 Controller provides the necessary intelligence to ensure that the transfer switch operates properly through a series of programmed sensing and timing functions.

### Features, Benefits and Functions

#### Standard Features

- Auxiliary relay contacts:
  - Source 1 Present 2NO & 2NC
  - Source 2 Present 2NO & 2NC
- Switch position indication contacts:
  - Source 1 Position 1NO & 1NC
  - Source 2 Position 1NO & 1NC
- Source 1 & Source 2 sensing:
  - Undervoltage/underfrequency
  - Overvoltage/overfrequency
  - 3-phase rotation protection
  - 3-phase voltage unbalance/loss
- Pre-transfer signal contacts 1NO/1NC.
- Go to Emergency (Source 2).
- Seven field programmable time delays.
- LCD-based display for programming, system diagnostic and Help message display.
- Mimic diagram with source available and connected LED indication.
- Time-stamped history log.
- System test pushbutton.

- Programmable plant exerciser — OFF, daily, 7, 14, 28-day interval selectable run time 0 – 600 minutes no load/load with fail-safe.
- Safe manual operation under full load with permanently affixed operating handle.
- Monitor Utility and Generator power source voltages and Generator power source frequency.
- Provide undervoltage protection of the Utility and Generator power sources.
- Provide underfrequency and overfrequency protection of the and Generator power source.
- Permit easy customer set-up.
- Permit system testing.
- Provide faceplate source status indications.

TABLE 34. CONTROLLER SETTINGS

DESCRIPTION	RANGE	FACTORY DEFAULT	FIXED/JUMPER
Time Delay Engine Start	3 Seconds	3 Seconds	Fixed Setting
Time Delay Normal to Emergency	2 or 15 Seconds	15 Seconds	Jumper-Selectable
Time Delay Emergency to Normal	5 Minutes	5 Minutes	Fixed Setting
Time Delay Engine Cool-off	5 Minutes	5 Minutes	Fixed Setting
Time Delay Emergency Fail Timer	6 Seconds	6 Seconds	Fixed Setting
Nominal Frequency	50 or 60 Hz	As Ordered	Jumper-Selectable
Nominal Voltage	120, 208, 220, 230, 240, 380, 415 or 480 Volts	As Ordered	Jumper-Selectable
Three-Phase or Single-Phase	1 or 3	As Ordered	Jumper-Selectable
Utility Undervoltage Dropout	80% of Nominal Voltage	80% of Nominal Voltage	Fixed Setting
Generator Undervoltage Dropout	80% of Nominal Voltage	80% of Nominal Voltage	Fixed Setting
Utility Undervoltage Pickup	90% of Nominal Voltage	90% of Nominal Voltage	Fixed Setting
Generator Undervoltage Pickup	90% of Nominal Voltage	90% of Nominal Voltage	Fixed Setting
Generator Underfrequency Dropout	90% of Nominal Frequency	90% of Nominal Frequency	Fixed Setting
Generator Underfrequency Pickup	95% of Nominal Frequency	95% of Nominal Frequency	Fixed Setting
Generator Overfrequency Dropout	Off or 115% of Nominal Frequency	Off	Jumper-Selectable
Generator Overfrequency Pickup	Off or 110% of Nominal Frequency	Off	Jumper-Selectable
Generator Test On/Off	Off, No Load Transfer, Load Transfer	Off	Jumper-Selectable
Generator Test Interval	7-Day, 14-day, or 28-day	7-Day	Jumper-Selectable
Engine Run Test Time	15 Minutes	15 Minutes	Fixed Setting

## Product Specifications

**TABLE 35. ATC-100 CONTROLLER SPECIFICATIONS**

DESCRIPTION	SPECIFICATION
Input Control Voltage	95 to 145 Vac 50/60 Hz
Voltage Measurements of	Utility $V_{AB}$ Generator $V_{AB}$ Utility $V_{BC}$ Generator $V_{BC}$ Utility $V_{CA}$ Generator $V_{CA}$
Voltage Measurement Range	0 to 575 Vac rms (50/60 Hz)
Voltage Measurement Accuracy	±1% of Full Scale
Frequency Measurements of	Generator
Frequency Measurement Range	40 Hz to 70 Hz
Frequency Measurement Accuracy	±0.3 Hz Over the Measurement Range
Undervoltage Dropout	80% of the Nominal System Voltage
Undervoltage Pickup	90% of the Nominal System Voltage
Underfrequency Dropout Range	90% of the Nominal System Frequency
Underfrequency Pickup Range	95% of the Nominal System Frequency
Overfrequency Dropout Range	115% of the Nominal System Frequency
Overfrequency Pickup Range	110% of the Nominal System Frequency
Operating Temperature Range	-20 to +70°C (-4 to +158°F)
Storage Temperature Range	-30 to +85°C (-22 to +185°F)
Operating Humidity	0 to 95% Relative Humidity (Non-condensing)
Operating Environment	Resistant to Ammonia, Methane, Nitrogen, Hydrogen and Hydrocarbons
Generator Start Relay	5 A, 1/6 hp @ 250 Vac 5 A @ 30 Vdc with a 150 W Maximum Load
K1, K2 Relays	10 A, 1 – 3 hp @ 250 Vac 10 A @ 30 Vdc
Applicable Testing	UL Recognized Component UL 1008, UL 991 Environmental IEC 61000-4-2, 61000-4-3, 61000-4-4, 61000-4-5, 61000-4-6, 61000-4-11 CISPR 11, Class B FCC Part 15, Class B
Enclosure Compatibility	NEMA 1, NEMA 3R and NEMA 12 UV Resistant ATC-100 Faceplate

## ATC-300 Controller



ATC-300 Controller

### Product Description

AT3 switches are equipped with the high-performance ATC-300 digital transfer controller for rock-solid monitoring, status reporting and transfer control operation. Superior design and robust construction make the AT3 the industry benchmark for critical and distributed power systems.

### Application Description

The Cutler-Hammer AT3 Automatic Transfer Switch from Eaton's electrical business is designed to provide unmatched performance, reliability and versatility for critical standby power applications.

### Features, Benefits and Functions

#### Standard Features

- Auxiliary relay contacts:
  - Source 1 Present 2NO & 2NC
  - Source 2 Present 2NO & 2NC
- Switch position indication contacts:
  - Source 1 Position 1NO & 1NC
  - Source 2 Position 1NO & 1NC
- Source 1 & Source 2 sensing:
  - Undervoltage/underfrequency
  - Overvoltage/overfrequency
  - 3-phase rotation protection
  - 3-phase voltage unbalance/loss
- Pre-transfer signal contacts 1NO/1NC.
- Go to Emergency (Source 2).
- Seven field programmable time delays.
- LCD-based display for programming, system diagnostic and Help message display.
- Mimic diagram with source available and connected LED indication.
- Time-stamped history log.
- System test pushbutton.
- Programmable plant exerciser — OFF, daily, 7, 14, 28-day interval selectable run time 0 – 600 minutes no load/load with fail-safe.
- Safe manual operation under full load with permanently affixed operating handle.

#### Optional Features

- Suitable for Use as Service Equipment in the standard enclosure size.
- Available TVSS surge suppression for power/controller, engine start circuit, phone and cable connections.
- Integrated distribution panels.
- Field-selectable multi-tap transformer panel permits operation on a wide range of system voltages.
- Integral overcurrent protection.
- Space heater with thermostat.
- Ammeter — load side.
- Stainless steel cover for controller.

TABLE 36. PROGRAMMING SELECTIONS

PARAMETERS	SET POINTS
TDNE	0 to 1800 Seconds
TDEN	0 to 1800 Seconds
TDEC	0 to 1800 Seconds
TDES	0 to 120 Seconds
TDN	0 to 120 Seconds
TDEF	0 to 6 Seconds
In Phase	Enabled or Disabled
In Phase Frequency Difference	0.0 to 3.0 Hz
Sync Time	1 to 60 Minutes
Pre-Transfer Signal Service	0 to 120 Seconds
Plant Exerciser	Disabled, 7, 14 or 28 Day Interval, 0 – 600 Minutes, Load or No Load
Sensing	3-phase or 1-phase
System Selection	Utility — Utility or Utility — Generator
PT Ratio	2:1 to 500:1
Commit to Transfer in TDNE	0 or 1
Re-Transfer Mode	Automatic or Manual
Engine Test Mode	Disabled, Load or No Load

### Product Specifications

TABLE 37. ATC-300 CONTROLLER SPECIFICATIONS

DESCRIPTION	SPECIFICATION
Input Control Voltage	65 to 145 Vac 50/60 Hz
Voltage Measurements of	Source 1 $V_{AB}$ Source 2 $V_{AB}$ Source 1 $V_{BC}$ Source 2 $V_{BC}$ Source 1 $V_{CA}$ Source 2 $V_{CA}$
Voltage Measurement Range	0 to 790 Vac rms (50/60 Hz)
Voltage Measurement Accuracy	±2% of Nominal Input Voltage
Frequency Measurement for	Source 1 and Source 2
Frequency Measurement Range	40 Hz to 70 Hz
Frequency Measurement Accuracy	±0.1 Hz
Undervoltage Dropout Range	50% to 90% of Nominal Voltage
Undervoltage Pickup Range	(Dropout +2%) to 99% of the Nominal System Voltage
Overvoltage Dropout Range	105% to 120% of Nominal Voltage
Overfrequency Pickup Range	101% to (Dropout -1 Hz) of the Nominal System Frequency
Underfrequency Dropout Range	90 to 97% of the Nominal System Frequency
Underfrequency Pickup Range	(Dropout +1 Hz) to 99% of the Nominal System Frequency
Overfrequency Dropout Range	103 to 110% of the Nominal System Frequency
Overfrequency Pickup Range	101% to (Dropout -1 Hz) of the Nominal System Frequency
Operating Temperature Range	-20 to +70°C (-4 to +158°F)
Storage Temperature Range	-30 to +85°C (-22 to +185°F)
Operating Humidity	0 to 95% Relative Humidity (Non-condensing)
Operating Environment	Resistant to Ammonia, Methane, Nitrogen, Hydrogen and Hydrocarbons
Generator Start Relay	5 A, 1/6 hp @ 250 Vac / 5 A @ 30 Vdc with a 150 W Maximum Load
K1, K2, Pretransfer, Alarm Relays	10 A, 1 – 3 hp @ 250 Vac / 10 A @ 30 Vdc
Applicable Testing	UL Recognized Component Meets Intent of UL 991, 1008 Meets IEC 1000-4-2, 1000-4-3, 1000-4-4, 1000-4-5, 1000-4-6, 1000-4-11 Meets CISPR 11, Class A Complies with FCC Part 15, Class A
Enclosure Compatibility	NEMA 1, NEMA 3R, and NEMA 12 UV Resistant ATC-300 Faceplate

# ATC-600 Controller

## IQ Transfer Controller



ATC-600

### Product Description

Eaton's Cutler-Hammer ATC-600 is a microprocessor-based logic controller to be used with Cutler-Hammer transfer switches. This device is door-mounted and provides the operator with an at-a-glance overview of switch status and parameters, as well as key diagnostic data. Real-time values for volts and frequency can be viewed via the front panel LED display, along with an indication of the power source currently in use.

The ATC-600 continuously monitors either single-phase or 3-phase voltages for Source 1, Source 2, and the load. When the Source 1 voltage or frequency is detected to be below the customer programmed set points, transfer to Source 2 is initiated. When the Source 2 voltage and frequency are detected to be within the programmed parameters, the transfer occurs. While the load is connected to Source 2, the ATC-600 continues to monitor Source 1. As soon as the Source 1 voltage and frequency return to within the programmed limits, and after a programmed time delay, a re-transfer back to Source 1 is initiated.

The ATC-600 uses microprocessor technology to provide the operator with a vast array of selections. Depending on the application, the user can "customize" the ATC-600 to meet the particular application. A summary of several key selections is listed in **Table 38**.

### Application Description

The ATC-600 is equipped to display history information either via the front panel or over PowerNet. Source 1 and Source 2 Run Time, Available Time, and Connect Time are available, as well as Load Energized Time, Number of Transfers, and the Date, Time and Reason for the Last 16 Transfers.

For communications capability, the ATC-600 can be equipped with a PONI card which will allow the user to communicate with the unit via Series III software. All settings for purchased options can be set from the faceplate of the unit or downloaded over PowerNet. Series III software allows for charting of key historical data, as well as providing the capability to monitor and control the transfer switch from a remote location.

For further information on PowerNet products and software, see **Section 25** of Eaton's 14th edition of the *Consulting Application Guide*.

**TABLE 38. PROGRAMMING SELECTIONS**

PARAMETERS	SET POINTS
TDNE	0 to 1800 Seconds
TDEN	0 to 1800 Seconds
TDEC	0 to 1800 Seconds
TDES	0 to 120 Seconds
TDN ①	0 to 120 Seconds or Based on Load Voltage Decay (2 – 30% of Nominal Voltage)

① Optional features.

**TABLE 38. PROGRAMMING SELECTIONS (CONTINUED)**

PARAMETERS	SET POINTS
TDEF	0 to 6 Seconds
In Phase	Enabled or Disabled
IPFD ②	0.0 to 3.0 Hz
SYNC ③	1 to 60 Minutes
Load Sequencing ①	Up to 10 Devices (Via Subnetwork)
Pre-Transfer Signal Device ①	0 to 120 Seconds Up to 10 Devices (Via Subnetwork)
Plant Exerciser ①	Load or No Load Transfer (Selectable)
Preferred Source Selector ①	Source 1 or Source 2 or None
Sensing	3-Phase or 1-Phase
System Selection	Utility/Generator or Dual Utility or Dual Generator

② In Phase Frequency Difference.

③ Sync Time Allowance.

### Product Specifications

**TABLE 39. SPECIFICATIONS**

DESCRIPTION	SPECIFICATION
Input Control Power Range	65 Vac rms to 160 Vac rms (50/60 Hz)
Voltage Measurements of	Source 1 $V_{AB}$ Source 2 $V_{AB}$ Load $V_{AB}$ Source 1 $V_{BC}$ Source 2 $V_{BC}$ Load $V_{BC}$ Source 1 $V_{CA}$ Source 2 $V_{CA}$ Load $V_{CA}$
Voltage Measurement Range	0 to 790 Vac rms (50/60 Hz)
Voltage Measurement Accuracy	±2% of Nominal Input Voltage
Frequency Measurement for	Source 1 and Source 2
Frequency Measurement Range	40 Hz to 80 Hz
Frequency Measurement Accuracy	±0.1 Hz
Undervoltage Sensing	Source 1 and Source 2
Undervoltage Dropout Range	50% to 90% of Nominal Voltage
Overvoltage Dropout Range ④	105% to 120% of Nominal Voltage
Underfrequency Dropout Range ④	90% to 100% of Nominal Frequency
Overfrequency Dropout Range ④	100% to 120% of Nominal Frequency
<b>Contact Outputs:</b>	
Two Form A Contacts for Generator start	5 A 250 Vac; 5 A 30 Vdc
Four Form A Contacts for Control Functions	10 A 250 Vac; 10 A 30 Vdc
Three Form C Contacts for Control Functions	10 A 250 Vac; 10 A 30 Vdc
Communications Output Over PowerNet (Optional)	PONI (Product Operated Network Interface)
<b>Front Panel Indications:</b>	
Automatic Mode	Blinking LED Indicates Automatic Operation
Test Mode	LED Illuminated Indicating the Unit is in the TEST Mode
Program Mode	LED Illuminated Indicating the Unit is in the Program Mode Blinking LED Indicates User is Viewing Set Points in Program Mode
LED Lights to Indicate	Source 1 Available (Amber), Source 2 Available (Amber), Source 1 Connected (Green), Source 2 Connected (Red), Source 1 Preferred (Red), Source 2 Preferred (Red), Load Energized (Red)
LED Display to Indicate	History Information, Set Points, Real-Time Clock
Environmental Temperature Range	Operation: -20°C to +70°C Storage: -30°C to +85°C
Applicable Standards	UL 1008, UBC and BOCA for Seismic Zone 4

④ Optional features.

## ATC-800 Controller

### Closed Transition IQ Transfer Controller



ATC-800

#### Product Description

The Closed Transition IQ Transfer [CTIQ Transfer (ATC-800)] is a programmable, microprocessor-based monitoring device designed for use in Eaton Closed Transition Transfer Switches (CTVI/CBVI). By using the Eaton CTIQ Transfer (ATC-800), the user may avoid intentional interruption of power when both sources of power are available. This make-before-break mode of operation is useful during testing of the engine generator under load and where a predetermined transfer to the generator is desired. Source paralleling duration is limited to less than 100 msec.

#### Passive Closed Transition

The Closed Transition mode of operation requires that both power sources be synchronized in voltage, frequency and phase angle within prescribed limits. Eaton's CTIQ Transfer (ATC-800) utilizes a technique that involves waiting for synchronization of the two sources without actively controlling the generator's voltage or frequency. The mode of operation is anticipatory in that the switch close command is initiated before the sources are exactly in-phase. Utilizing the phase angle and frequency difference between the two sources, a calculation is made to predict when both sources would be in-phase. The response time of the switch is then factored in to determine when the switch close signal should be given to assure optimal closure of the two sources in-phase.

The Eaton Closed Transition IQ Transfer (ATC-800) must be selected with one of two feature sets: 47C or 47D. The difference between these two feature sets is the action taken by the CTIQ Transfer (ATC-800) if it is determined that the two sources will not achieve synchronization. If Feature set 47C is selected, failure to synchronize results in the switch reverting to an Open Transition mode of operation. However, if Feature set 47D is selected, failure to synchronize will result in the CTIQ Transfer (ATC-800) refusing to Transfer to Source 2 and an alarm signal being activated. In neither case will there be a paralleling of sources if synchronization is not achieved.

#### Application Description

- The generator used with a closed transition transfer switch must be equipped with an isochronous governor.
- When paralleling sources, fault current contributions from both sources should be considered in the system design.
- Closed Transition (make-before-break) technology causes paralleling with the Source 1. It is the user's responsibility to comply with any requirements regarding protective relaying. Protective relaying is not supplied with the standard transfer switch, but is available.

#### Switch Application Section

##### Eaton Closed Transition IQ Transfer (ATC-800) Features

The CTIQ Transfer (ATC-800) is a door-mounted, totally enclosed device that is customer accessible from the transfer switch front panel.

Data access and programming operations are performed using the CTIQ (ATC-800) Transfer's touch-sensitive function buttons in conjunction with an easy-to-read, illuminated, alphanumeric LED display. Both the function buttons and the display window are part of the device's front panel. A built-in Help button provides user assistance in the form of message displays.

The CTIQ Transfer (ATC-800) is communications ready and compatible with all Eaton IQ devices as well as the Eaton PowerNet system-wide supervisory and control software. This permits monitoring and control of several transfer switches, locally or remotely, from a single point.

#### Features, Benefits and Functions

##### Additional Features

- Source paralleling duration is limited to 100 msec. or less.
- Applicable for use on any low or medium voltage application through 38 kV.
- True rms three-phase voltage sensing on Normal, Source 2 and Load.
- Frequency sensing on Normal and Source 2.
- Programmable set points stored in non-volatile memory.
- PowerNet Communication to personal computer either on-site or remote.
- Historical data on most recent transfers (up to 16 events) viewable at switch. Unlimited history storage (remote) available when used with PowerNet software.
- Wide range of user-selectable option combinations.
- Load sequencing.
- Engine start contacts.
- Engine Test Switch with user-selectable Test Mode and Fail-Safe.
- Alarm contact (multiple alarm functions available).
- Pre-transfer signal.
- Heartbeat Monitor (flashing green Automatic light signifies that the CTIQ Transfer (ATC-800) is operating properly).
- Instrumentation:
  - Voltmeter (Accuracy  $\pm 1\%$ )
  - Reads line-to-line on Sources 1 and 2 and Load
  - Frequency Meter (40 – 80 Hz, accuracy  $\pm 1$  Hz)
  - Source Available Time (both sources)
  - Source Connected Time (both sources)
  - Source Run Time

#### ATC-800 Programming

##### Button Functions

Three buttons provide easy access to all commonly used CTIQ Transfer (ATC-800) functions.

When the preferred source is connected and the ATS is operating normally, the Automatic indicator light will be flashing and the display window will be blank.

Using the Display Select button, the operator can step through each of the six display families:

- Source 1.
- Source 2.
- Load.
- History.
- Time/Date.
- Set Points.

##### Note:

Stepping through the various display modes does not alter preset values or otherwise affect operation of the ATS.

## ATC-800 Closed Transition IQ Transfer Controller

Once the desired display family is selected, the user may press the Step button to cycle through specific parameters or metered values shown in the display window.

### Initial Programming

Factory programming will load all customer specified functions and presets. At the customer's request, Eaton will add, delete or adjust optional features.

### Customer Programming

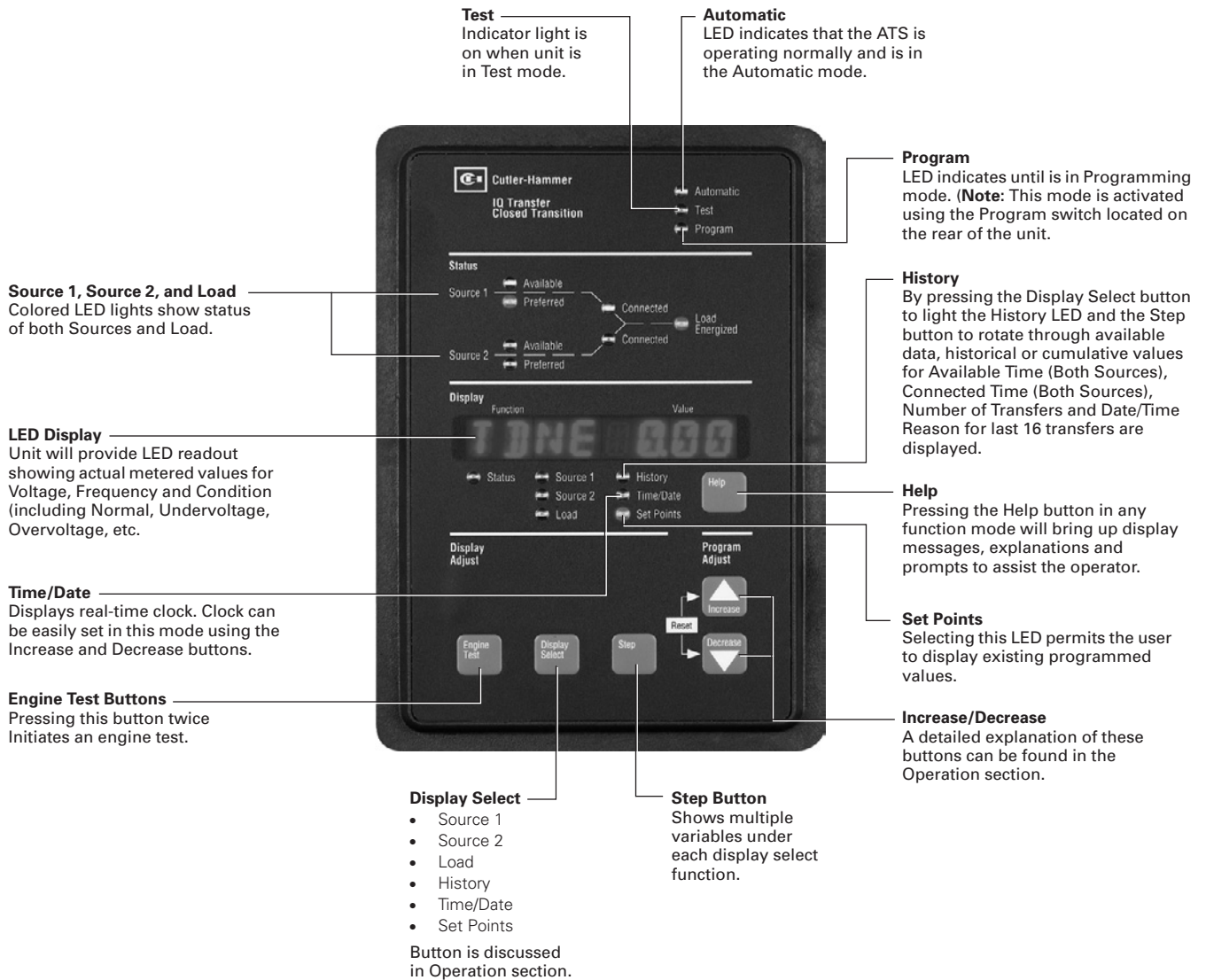
Customers may reprogram set points and other parameters to match their application, using the Program switch located on the rear of the unit. Once the programming mode has been activated and the Program

light is flashing, the user may access Set Point settings by pressing the Display Select button until the Set Points LED is illuminated. Values for individual set points may then be altered by pressing the Increase or Decrease buttons. Once a parameter has been reset, the user advances to the next set point by pressing the Step button.

While the CTIQ Transfer (ATC-800) is in the Program mode, the device continues to operate in accordance with the previously programmed set points and parameters. The unit is never off-line, and preset values do not change until programming has been completed.

Once reprogramming is complete, the user may return the Program switch to the Run position. At this point, all new values are stored in the CTIQ's (ATC-800) non-volatile memory, and the unit returns to Automatic mode.

## Closed Transition IQ Transfer (ATC-800) Front Panel Display and Button Functions



**Definitions**

**Closed Transition:** Closed transition is a feature that will temporarily parallel two live sources in a make-before-break scheme when performing a transfer. The CTIQ (ATC-800) Transfer will close the switching devices for both sources, paralleling both sources, for a maximum time of 100 milliseconds after the sources are synchronized.

**Open Transition/In-Phase Monitor:** In-Phase monitor is a feature that will allow a transfer between two sources only when the phase difference between the two sources is near zero. This is an open transition transfer that prevents inrush currents from exceeding normal starting currents in the case where motor loads are being transferred.

**Open Transition/Delayed with Load Voltage Decay:** Load voltage decay transfer is a feature that, after opening the switch for the original source, holds in the neutral position until the voltage on the load is less than 30% of rated voltage. This is an open transition that prevents inrush currents from exceeding normal starting currents in the case where motor loads are being transferred.

**Operation**

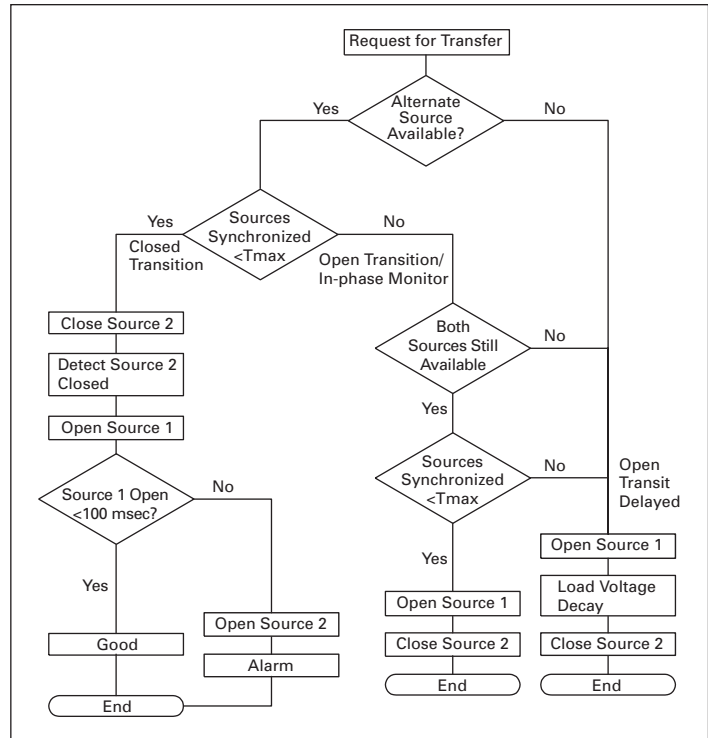
The Eaton CTIQ (ATC-800) Transfer operates in the following modes to meet most load management applications:

- Loss of Normal Power
  - Open Transition to Alternate Source
- Normal Power Restored
  - Closed Transition back to Normal Source
- Peak Shave (Remote or Local)
  - Closed Transition to and from Alternate Source
- Test (User Selectable)
  - Load Transfer — Closed Transition to and from Alternate Source
  - No-Load Transfer — Starts Alternate Power Source and Allows to Run Unloaded; No Transfer Takes Place

**Closed Transition Operation Modes**

**Feature Set 47C Closed/In-Phase/Load Voltage Decay**

CTIQ (ATC-800) Transfer controllers equipped with Feature Set 47C execute the following sequence of operations upon receipt of a request for transfer: the controller waits (for a pre-selected time frame) for synchronization of voltage and frequency. If achieved, a closed transition transfer occurs. Failure to synchronize results in the controller defaulting to an in-phase monitor, open transition, mode of operation. If the two sources fail to achieve frequency synchronization within the user selectable range, the controller defaults to an open transition using a Load Voltage Decay delayed transition.



**FIGURE 18. FEATURE SET 47C SCHEMATIC**

**TABLE 40. CLOSED TRANSITION/IN-PHASE STANDARD FEATURES**

<b>STANDARD FEATURES</b>	<b>CUSTOMER ADJUSTMENTS</b>
Closed Transition Frequency Difference (Hz)	0.0 to 0.3 Hz
Closed Transition Voltage Difference (Volts)	1 to 5%
In-phase Transition Frequency Difference (Hz)	0.0 to 0.3 Hz
Closed Transition Synchronization Timer	1 to 60 Minutes
In-phase Transition Synchronization Timer	1 to 60 Minutes

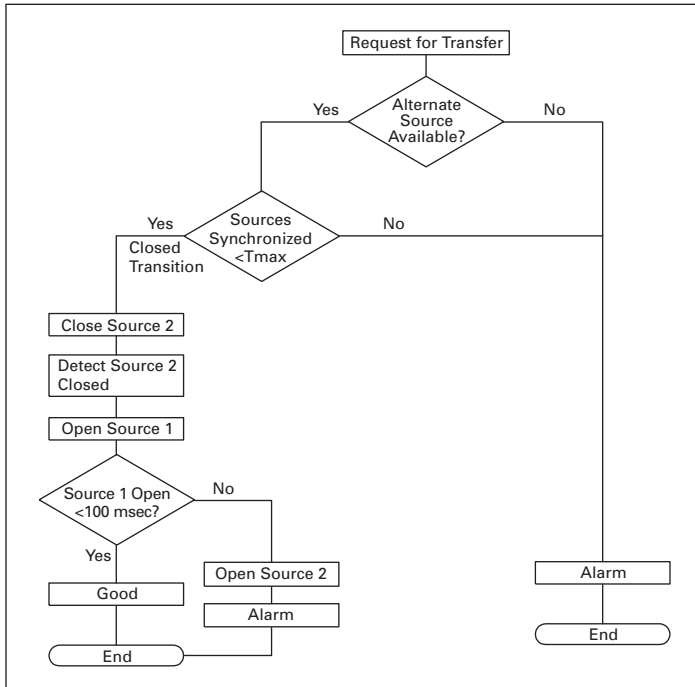
## In-Phase Transfer

### Feature Set 47D Closed Only

CTIQ (ATC-800) Transfer controllers equipped with Feature Set 47D only transfer to an alternate source when both sources are synchronized. For synchronization to occur, both voltage and frequency differentials must fall within the user selectable ranges. If synchronization does not occur (within a pre-selected amount of time) the controller will maintain load connection to the current power source and initiate an alarm.

**TABLE 41. CLOSED TRANSITION STANDARD FEATURES**

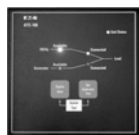
STANDARD FEATURES	CUSTOMER ADJUSTMENTS
Closed Transition Frequency Difference (Hz)	0.0 to 0.3 Hz
Closed Transition Voltage Difference	1 to 5%
Closed Transition Synchronization Timer	1 to 60 Minutes



**FIGURE 19. FEATURE SET 47D SCHEMATIC**

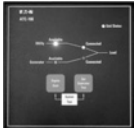



# ATC Controller — Selection Guide

**TABLE 42. ATC CONTROLLER FEATURE SELECTION CHART**



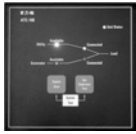



<b>FEATURE DESCRIPTION</b>	<b>ATC-100</b>	<b>ATC-300</b>	<b>ATC-600</b>	<b>ATC-800</b>
<b>Transition</b>				
Open Transition	Standard	Standard	Standard	Standard
Closed Transition	Not Available	Not Available	Not Available	Standard
<b>Timers</b>				
Time Delay Normal to Emergency (TDNE)	Standard	Standard	Standard	Standard
Time Delay Engine Start (TDES)	Standard	Standard	Standard	Standard
Time Delay Emergency to Normal (TDEN)	Standard	Standard	Standard	Standard
Time Delay Engine Cooldown (TDEC)	Standard	Standard	Standard	Standard
Time Delay Emergency Fail (TDEF)	Standard	Standard	Standard	Standard
<b>Engine/Generator exerciser</b>				
Plant Exerciser (PE) with Fail-Safe	Selectable — OFF, 7, 14, 28 Day Interval Selectable Run Time 0 – 600 Minutes No Load/Load with Fail-safe	Programmable — OFF, Daily, 7, 14, 28 Day Interval Selectable Run Time 0 – 600 Minutes No Load/Load with Fail-safe	Programmable — OFF, Daily, 7, 14, 28 Day Interval Selectable Run Time 0 – 600 Minutes No Load/Load with Fail-safe	Programmable — OFF, Daily, 7, 14, 28 Day Interval Selectable Run Time 0 – 600 Minutes No Load/Load with Fail-safe
<b>Source 1 Sensing</b>				
All-Phase Undervoltage and Underfrequency Protection	Standard	Standard	Standard	Standard
All-Phase Overvoltage and Overfrequency Protection	Standard	Standard	Standard	Standard
Three-Phase Rotation Sensing	Not Available	Standard	Standard	Standard
Three-Phase Voltage Unbalance/Loss	Not Available	—	—	—
<b>Source 2 Sensing</b>				
All-Phase Undervoltage and Underfrequency Protection	Standard	Standard	Standard	Standard
All-Phase Overvoltage and Overfrequency Protection	Standard	Standard	Standard	Standard
Three-Phase Rotation Sensing	Not Available	Standard	Standard	Standard
Three-Phase Voltage Unbalance/Loss	Not Available	—	—	—
<b>Manual Controls</b>				
Test Operators	Standard	Standard	Standard	Standard
4-Position Test Selector Switch (FPSS)	Not Available	Optional	Optional	Optional
Time Delay Bypass Pushbutton	Standard	Standard	Standard	Standard
Maintenance Selector Switch (MSS)	Not Available	Not Available	Not Available	Not Available
Automatic/Manual Operation Selector Switch	Not Available	Optional	Optional	Optional
Automatic Transfer or Automatic Transfer with Non-Automatic Re-Transfer Operation	Not Available	Optional	Optional	Optional
<b>Indications/and Status Display</b>				
Source 1 Connected/Source 2 Connected	Standard	Standard	Standard	Standard
Source 1 Present/Source 2 Present	Standard	Standard	Standard	Standard
Source 1 Tripped/Source 2 Tripped	Standard	Standard	Standard	Standard
<b>Customer Outputs</b>				
Source 1/Source 2 Present Contacts	Not Available	Optional 2NO & 2NC	Optional 2NO & 2NC	Optional 2NO & 2NC
Source 1/Source 2 Present Contacts	Not Available	Optional 2NO & 2NC	Optional 2NO & 2NC	Optional 2NO & 2NC
Source 1 Available/Source 2 Available Contacts	Not Available	Optional 2NO & 2NC	Optional 2NO & 2NC	Optional 2NO & 2NC
<b>Switch Position Indication Contact</b>				
Source 1 Position Indication Contact	Not Available	2NO & 2NC	2NO & 2NC	2NO & 2NC
Source 1 Position Indication Contact	Not Available	2NO & 2NC	2NO & 2NC	2NO & 2NC
Pre-Transfer Signal Contacts	—	Standard 1NO & 1NC	Standard 1NO & 1NC	Standard 1NO & 1NC
<b>Customer Inputs</b>				
Go to Emergency (Source 2)	—	—	—	—
Load Shed	Not Available	Not Available	Optional	Optional

**TABLE 42. ATC CONTROLLER FEATURE SELECTION CHART (CONTINUED)**

<b>FEATURE DESCRIPTION</b>	 <b>ATC-100</b>	 <b>ATC-300</b>	 <b>ATC-600</b>	 <b>ATC-800</b>
<b>Switch Position Indication Contact</b>				
Source 1 Position Indication Contact	Not Available	2NO & 2NC	2NO & 2NC	2NO & 2NC
Source 1 Position Indication Contact	Not Available	2NO & 2NC	2NO & 2NC	2NO & 2NC
Pre-Transfer Signal Contacts	—	Standard 1NO & 1NC	Standard 1NO & 1NC	Standard 1NO & 1NC
<b>Customer Inputs</b>				
Go to Emergency (Source 2)	—	—	—	—
Load Shed	Not Available	Not Available	Optional	Optional
<b>Integral Overcurrent Protection</b>				
Source 1, Source 2 or Both	—	Optional	Optional	Optional
<b>Metering</b>				
DP400 Monitoring Voltage, Amps, Frequency, Power Factor, Harmonic Distortion on Source 1 and Source 2	Not Available	Optional	Optional	Optional
IQ Analyzer Monitoring Voltage, Amps, Frequency, Power Factor, Harmonic Distortion on Source 1 and Source 2 with Waveform Capture	Not Available	Optional	Optional	Optional
Ammeter — Load Side (Digital, All-Phases Metered)	Not Available	Optional	Optional	Optional
Rear Bus Connections	Not Available	Optional	Optional	Optional
Optional Terminals	Not Available	Optional	Optional	Optional
<b>Transfer Mode Open Transition</b>				
Time Delay Neutral	Not Available	Optional	Optional	Optional
In-Phase Monitoring	Standard	Optional	Optional	Optional
Load Voltage Decay	Not Available	Optional	Optional	Optional
<b>Transfer Mode Closed Transition</b>				
Time Delay Neutral	Not Available	Not Available	Not Available	Optional
In-Phase Monitoring	Not Available	Not Available	Not Available	Optional
Load Voltage Decay	Not Available	Not Available	Not Available	Optional
<b>Service Entrance Rating</b>				
Source 1, Source 2 or Both & With and Without Ground Fault Protection	Optional	Optional	Optional	Optional
<b>Stainless Steel Cover</b>				
SS Lockable Cover for Controller	Not Available	Optional	Optional	Optional
Integral Distribution Panel	—	Optional	Not Available	Not Available
<b>Space Heater with Thermostat</b>				
100 Watts	Not Available	Optional	Optional	Optional
400 Watts	Not Available	Optional	Optional	Optional
<b>Building Codes</b>				
Seismic Zone 4 Certified (BOCA, CBC, IBC, UBC)	Standard	Standard	Standard	Standard
Communications	Not Available	Not Available	Optional	Optional
<b>Transient Voltage Surge Protection</b>				
Single-Phase	Optional	Optional	Optional	Optional
Three-Phase	Optional	Optional	Optional	Optional
Password Protection	—	Standard	Standard	Standard

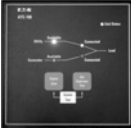



# ATC Controller — Selection Guide

**TABLE 43. ATC CONTROLLER SPECIFICATION SELECTION CHART**

SPECIFICATION DESCRIPTION								
	ATC-100	FACTORY DEFAULT SETTINGS	ATC-300	FACTORY DEFAULT SETTINGS	ATC-600	FACTORY DEFAULT SETTINGS	ATC-800	FACTORY DEFAULT SETTINGS
<b>Programming Selections</b>								
Time Delay Normal to Emergency	3 Seconds (Fixed)	—	0 – 1800 Seconds	0:00	0 – 1800 Seconds	0:00	0 – 1800 Seconds	0:00
Time Delay Emergency to Normal	7 Minutes (Fixed)	—	0 – 1800 Seconds	5:00	0 – 1800 Seconds	5:00	0 – 1800 Seconds	5:00
Time Delay Engine Cooldown	5 Minutes (Fixed)	—	0 – 1800 Seconds	5:00	0 – 1800 Seconds	5:00	0 – 1800 Seconds	5:00
Time Delay Engine Start	10 Seconds (Fixed)	—	0 – 120 Seconds	0:03	0 – 120 Seconds	0:03	0 – 120 Seconds	0:03
Time Delay Neutral	N/A	—	0 – 120 Seconds	0:00	0 – 120 Seconds or Based on Load Voltage Decay of 2% – 30% of Nominal	0:00	0 – 120 Seconds or Based on Load Voltage Decay of 2% – 30% of Nominal	0:00
Time Delay Source 2 Fail	N/A	—	0 – 6 Seconds	0:06	0 – 6 Seconds	0:06	0 – 6 Seconds	0:06
Time Delay Voltage Unbalance	N/A	—	10 – 30 Seconds	20	N/A	20	N/A	20
Voltage Unbalance Three-Phase	N/A	—	0 or 1 (1 = Enabled)	1	—	1	—	1
% of Unbalanced Voltage Dropout	N/A	—	5% to 20% (DO) Dropout -2% to 3% (PU)	20%	N/A	20%	N/A	20%
Phase Reversal Three-Phase	N/A	—	OFF, ABC, CBA	Off	N/A	Off	N/A	Off
In-Phase	N/A	—	0 or 1 (1 = Enabled)	0	Enabled or Disabled	0	Enabled or Disabled	0
Load Sequencing	N/A	—	N/A	—	Up to 10 Devices (via Sub-Network)	—	Up to 10 Devices (via Sub-Network)	—
Pre-Transfer Signal	N/A	—	1 – 120 Seconds (Form “C” Contact)	0:00	0 – 120 Seconds (Up to 10 Devices via Sub-Network)	0:00	0 – 120 Seconds (Up to 10 Devices via Sub-Network)	0:00
Plant Exerciser	Selectable Day, Off, 7, 14, 28-Day Interval, 15 Minutes Run Time, No Load	Off	Selectable — Off, Daily or 7, 14, 28 Day Intervals, 0 – 600 Minutes, Load or No Load	Off	Selectable — Disabled or 7-Day Interval, 0 – 600 Minutes, Load or No Load	Off	Selectable — Disabled or 7-Day Interval, 0 – 600 Minutes, Load or No Load	Off
Preferred Source Selection	N/A	—	N/A	—	Source 1 or 2 or None	—	Source 1 or 2 or None	—
Commitment to Transfer in TDNE	N/A	—	N/A	—	Enabled or Disabled	—	Enabled or Disabled	—
Re-Transfer Mode	N/A	—	N/A	—	Automatic or Manual	—	Automatic or Manual	—
Auto Daylight Savings Time Adjustment	N/A	—	0 or 1 (1 = Enabled)	1	—	1	—	1
System Selection	Utility/Generator or Dual Utility	—	Utility/Generator or Dual Utility	—	Utility/Generator or Dual Utility or Dual Generator	—	Utility/Generator or Dual Utility or Dual Generator	—
Additional Information	PA01600002E	—	TD01602006E	—	TD.15A.05.T.E.	—	TD.15A.05.T.E.	—

**Note:**  
Features are order specific. Not all features are supplied as standard.

**TABLE 43. ATC CONTROLLER SPECIFICATION SELECTION CHART (CONTINUED)**

SPECIFICATION DESCRIPTION		FACTORY DEFAULT SETTINGS		FACTORY DEFAULT SETTINGS		FACTORY DEFAULT SETTINGS		FACTORY DEFAULT SETTINGS
	ATC-100		ATC-300		ATC-600		ATC-800	
<b>System Application Voltage</b>	120/240 V, 208 V <sup>①</sup>	—	Up to 600 Vac	600 Vac	Up to 600 Vac	600 Vac	Up to 600 Vac	600 Vac
<b>Voltage Specifications</b>								
Voltage Measurements of:	Source 1 and 2	—	Source 1 and 2 — $V_{AB}$ , $V_{BC}$ and $V_{CA}$	—	Source 1, 2 and Load — $V_{AB}$ , $V_{BC}$ and $V_{CA}$	—	Source 1, 2 and Load — $V_{AB}$ , $V_{BC}$ and $V_{CA}$	—
Voltage Measurement Range	120 – 240 Vac	—	0 – 790 Vac rms	—	0 – 790 Vac rms	—	0 – 790 Vac rms	—
Operating Power	95 – 145 Vac	—	65 – 145 Vac	—	65 – 145 Vac	—	65 – 145 Vac	—
<b>Frequency Specifications</b>								
Frequency Measurements of:	Source 2	—	Source 1 and 2	—	Source 1 and 2	—	Source 1 and 2	—
Frequency Measurement Range	50 – 60 Hz	—	40 – 70 Hz	—	40 – 70 Hz	—	40 – 70 Hz	—
<b>Environmental Specifications</b>								
Operating Temperature Range	-20° to +70°C	—	-20° to +70°C	—	-20° to +70°C	—	-20° to +70°C	—
Storage Temperature Range	-30° to +85°C	—	-30° to +85°C	—	-30° to +85°C	—	-30° to +85°C	—
<b>Operating Humidity</b>	0 to 95% Relative Humidity (Non-condensing)	—	0 to 95% Relative Humidity (Non-condensing)	—	0 to 95% Relative Humidity (Non-condensing)	—	0 to 95% Relative Humidity (Non-condensing)	—
<b>Operating Environment</b>	Resistant to Ammonia, Methane, Nitrogen, Hydrogen and Hydrocarbons	—	Resistant to Ammonia, Methane, Nitrogen, Hydrogen and Hydrocarbons	—	Resistant to Ammonia, Methane, Nitrogen, Hydrogen and Hydrocarbons	—	Resistant to Ammonia, Methane, Nitrogen, Hydrogen and Hydrocarbons	—
<b>Front Panel Indication</b>								
Mimic Diagram With LED Indication	Unit Status. Source 1 and 2 Available and Connected (5 Total)	—	Unit Status. Source 1 and 2 Available and Connected (5 Total)	—	Automatic, Test and Program Mode. Source 1 and 2 Available, Connected and Preferred. Load Energized (10 Total)	—	Automatic, Test and Program Mode. Source 1 and 2 Available, Connected and Preferred. Load Energized (10 Total)	—
Main Display	N/A	—	LCD-based Display	—	LED Display	—	LED Display	—
Display Language	N/A	—	English, French	English	English	English	English	English
<b>Communications Capable</b>	N/A	—	N/A	<sup>②</sup>	PONI/INCOM™	<sup>②</sup>	PONI/INCOM	<sup>②</sup>
<b>Enclosure Compatibility</b>	NEMA 1 and 3R	—	NEMA 1, 12 and 3R, UV Resistant Faceplate	<sup>③</sup>	NEMA 1, 12, 3R and 4X UV Resistant Faceplate	<sup>③</sup>	NEMA 1, 12, 3R and 4X UV Resistant Faceplate	<sup>③</sup>
<b>Operating Environmental Range</b>	Operation -20°C to +70°C, Storage -30°C to +85°C, Humidity 0% to 95% Relative (Noncondensing)	—	Operation -20°C to +70°C, Storage -30°C to +85°C, Humidity 0% to 95% Relative (Noncondensing)	—	Operation -20°C to +70°C, Storage -30°C to +85°C, Humidity 0% to 95% Relative (Noncondensing)	—	Operation -20°C to +70°C, Storage -30°C to +85°C, Humidity 0% to 95% Relative (Noncondensing)	—

<sup>①</sup> Single-phase.  
<sup>②</sup> Transfer on customer input.  
<sup>③</sup> As ordered.

**Note:**  
 Features are order specific. Not all features are supplied as standard.

# Transfer Switch — Product Selection

TABLE 44. AUTOMATIC TRANSFER SWITCH FEATURES

FEATURE NUMBER	DESCRIPTION	WALL-MOUNT PRODUCT						FLOOR STANDING		CLOSED TRANSITION	SOFT LOAD	
		RLC1	ATV1 ATH1 ATC1	ATV3 ATH3	ATC3 ①	ATV1 ATH1	NTHE NTVE	MTHX MTVX	ATVIMG BIVIMG	CTVIMG	CTVCMG	
		RESIDENTIAL CONTACTOR SWITCH ATC-100 CONTROLLER	LIGHT COMMERCIAL MOLDED CASE DEVICE AND CONTACTOR DESIGN ATC-100 CONTROLLER	MOLDED CASE SWITCH ATC-300 CONTROLLER	CONTACTOR SWITCH ATC-300 CONTROLLER	MOLDED CASE DEVICE ATC-600 IQ TRANSFER	NON-AUTOMATIC TRANSFER SWITCH	MANUAL TRANSFER SWITCH	MAGNUM FIXED AND DRAWOUT MOUNT ATC-600 IQ TRANSFER	MAGNUM BYPASS ISOLATION ATC-600 IQ TRANSFER	MAGNUM FIXED AND DRAWOUT MOUNT ATC-800 CLOSED TRANSITION	MAGNUM LOAD FIXED AND DRAWOUT MOUNT ATC-5000 SOFT LOAD
1	<b>Timers</b> Time Delay Normal to Emergency (TDNE) Fixed 2 Seconds or 15 Seconds Adjustable 0 – 1800 Seconds	S	S	S	S	S			S	S	S	S
2	Time Delay Engine Start (TDES) Fixed 3 Seconds Adjustable 0 – 120 Seconds	S	S	S	S	S			S	S	S	S
3	Time Delay Emergency to Normal (TDEN) Fixed 1 Minute Adjustable 0 – 1800 Seconds	S	S	S	S	S			S	S	S	S
4	Time Delay Engine Cooldown (TDEC) Fixed 5 Minutes Adjustable 0 – 1800 Seconds	S	S	S	S	S			S	S	S	S
5	<b>Emergency (S2) Source Sensing</b>											
5H	Phase Reversal			S	S	0			0	0	0	0
5J	All Phase Undervoltage/Underfrequency	S	S	S	S	S			S	S	S	S
5K	All Phase Overvoltage/Overfrequency			S	S	S			S	S	S	S
5L	All Phase Voltage Unbalance and Phase Loss											
5N	All Phase Overfrequency	S	S									0
6	<b>System or Engine Test</b>											
6B	System Test Pushbutton	S	S	S	S	S			S	S	S	S
6D	Maintained 2-Position Test Switch					0			0	0	0	0
6H	Maintained 4-Position Test Switch					0			0	S	0	0
7	Time Delay Emergency Fail (TDEF) Fixed 6 Seconds Time Delay Emergency Fail (TDEF) Adjustable 0 – 6 Seconds	S	S	S	S	S			S	S	S	S
8	<b>Pushbutton Bypass</b>											
8C	Bypass TDEN			S	S	S			S	S	S	S
8D	Bypass TDNE			S	S	S			S	S	S	S
9	<b>Maintenance Selector Switch</b>											
9B	Electrical Operator Isolator Switch			0	0	0			0	0	0	0
10	<b>Preferred Source Selector Switch</b>											
10B	Utility to Utility or Utility to Generator					0			S	S	S	S
10D	Generator to Generator					0			S	S	S	S

① Consult factory for contactor rating availability.  
S = Standard, O = Optional

TABLE 44. AUTOMATIC TRANSFER SWITCH FEATURES (CONTINUED)

FEATURE NUMBER	DESCRIPTION	WALL-MOUNT PRODUCT						FLOOR STANDING		CLOSED TRANSITION	SOFT LOAD	
		RLC1	ATV1 ATH1 ATC1	ATV3 ATH3	ATC3 ①	ATV1 ATH1	NTHE NTVE	MTHX MTVX	ATVIMG	BIVIMG	CTVIMG	CTVCMG
		RESIDENTIAL CONTACTOR SWITCH ATC-100 CONTROLLER	LIGHT COMMERCIAL MOLDED CASE DEVICE AND CONTACTOR DESIGN ATC-100 CONTROLLER	MOLDED CASE SWITCH ATC-300 CONTROLLER	CONTACTOR SWITCH ATC-300 CONTROLLER	MOLDED CASE DEVICE ATC-600 IQ TRANSFER	NON-AUTOMATIC TRANSFER SWITCH	MANUAL TRANSFER SWITCH	MAGNUM FIXED AND DRAWOUT MOUNT ATC-600 IQ TRANSFER	MAGNUM BYPASS ISOLATION ATC-600 IQ TRANSFER	MAGNUM FIXED AND DRAWOUT MOUNT ATC-800 CLOSED TRANSITION	MAGNUM LOAD FIXED AND DRAWOUT MOUNT ATC-5000 SOFT LOAD
12	<b>Pilot Lights</b>											
12C	Normal (S1) Source Connected	S	S	S	S	S	S	S	S	S	S	S
12D	Emergency (S2) Source Connected	S	S	S	S	S	S	S	S	S	S	S
12G	Normal (S1) Source Available	S	S	S	S	S	S	S	S	S	S	S
12H	Emergency (S2) Source Available	S	S	S	S	S	S	S	S	S	S	S
12L	Normal (S1) Source Tripped (Requires Feature 16)			0		0	0		0	0	0	0
12M	Emergency (S2) Source Tripped (Requires Feature 16)			0		0	0		0	0	0	0
14	<b>Auxiliary Relay Contacts</b>											
14C	Normal (S1) Source Available 4 Form C					0						
14D	Emergency (S2) Source Available 4 Form C					0						
14E	Normal (S1) Source Available 1 Form C					S		S	S	S	S	S
14F	Emergency (S2) Source Available 1 Form C					S		S	S	S	S	S
14G	Normal (S1) Source Available 2 Form C	S	S	S								
14H	Emergency (S2) Source Available 2 Form C	S	S	S								
15	<b>Position Contacts</b>											
15E	Normal (S1) Source Position 1 Form C	0	S	0	0			S	S	S		
15F	Emergency (S2) Source Position 1 Form C	0	S	0	0			S	S	S		
15M	Source 2 Load Shed Contacts 4 Form C	0										
16	<b>Integral Overcurrent Protection</b>											
16N	Normal (S1) Switch Only			0		0	0	0	0	0	0	0
16E	Emergency (S2) Switch Only			0		0	0	0	0	0	0	0
16B	Normal (S1) and Emergency (S2) Switches			0		0	0	0	0	0	0	0
16S	Service Equipment/Overcurrent Protection (S1)	0										
18	<b>Metering</b>											
18O	IQ Analyzer Normal (S1)					0	0	0	0	0	0	0
18P	IQ Analyzer Emergency (S2)					0	0	0	0	0	0	0
18Q	IQ Analyzer Switch Selectable (S1) and (S2)					0	0	0	0	0	0	0
18V	IQ Analyzer Load Side					0	0	0	0	0	0	0
18R	IQ DP-4000 Normal (S1)					0	0	0	0	0	0	0
18S	IQ DP-4000 Emergency (S2)					0	0	0	0	0	0	0
18T	IQ DP-4000 Switch Selectable (S1) and (S2)					0	0	0	0	0	0	0
18U	IQ DP-4000 Load Side					0	0	0	0	0	0	0
18W	Load Side Ammeter			0	0							

① Consult factory for contactor rating availability.  
S = Standard, O = Optional

TABLE 44. AUTOMATIC TRANSFER SWITCH FEATURES (CONTINUED)

FEATURE NUMBER	DESCRIPTION	WALL-MOUNT PRODUCT						FLOOR STANDING		CLOSED TRANSITION	SOFT LOAD	
		RLC1	ATV1 ATH1 ATC1	ATV3 ATH3	ATC3 ①	ATV1 ATH1	NTHE NTVE	MTHX MTVX	ATVIMG	BIVIMG	CTVIMG	CTVCMG
		RESIDENTIAL CONTACTOR SWITCH ATC-100 CONTROLLER	LIGHT COMMERCIAL MOLDED CASE DEVICE AND CONTACTOR DESIGN ATC-100 CONTROLLER	MOLDED CASE SWITCH ATC-300 CONTROLLER	CONTACTOR SWITCH ATC-300 CONTROLLER	MOLDED CASE DEVICE ATC-600 IQ TRANSFER	NON-AUTOMATIC TRANSFER SWITCH	MANUAL TRANSFER SWITCH	MAGNUM FIXED AND DRAWOUT MOUNT ATC-600 IQ TRANSFER	MAGNUM BYPASS ISOLATION ATC-600 IQ TRANSFER	MAGNUM FIXED AND DRAWOUT MOUNT ATC-800 CLOSED TRANSITION	MAGNUM LOAD FIXED AND DRAWOUT MOUNT ATC-5000 SOFT LOAD
20A	Rear Bus Connections			0		0	0	0	0	0	0	0
21A	Non-Standard Terminals		0	0	0	0	0	0	0	0	0	0
23	<b>Plant Exerciser</b>											
23A	Selectable — Disabled/7, 14, 28 Day Interval, Fixed 15 Minutes, Load/No Load, with Fail-Safe	S	S									
23J	Selectable — Disabled/7 Day Interval, 0 – 600 Minutes, Load/No Load, with Fail-safe					S		S	S	S	S	S
23K	Selectable — Disabled/7, 14, 28 Day Interval, 0 – 600 Minutes, Load/No Load, with Fail-Safe			S	S							
26	<b>Normal (S1) Source Sensing</b>											
26D	Go to Emergency (S2) Input			S	S	S		S	S	S	S	S
26H	Phase Reversal Protection			S	S	0		0	0	0	0	0
26J	All Phase Undervoltage/Underfrequency			S	S	S		S	S	S	S	S
26K	All Phase Overvoltage/Overfrequency			S	S	S		S	S	S	S	S
26L	Three-Phase Voltage Unbalance/Phase Loss			S		0						
26M	Generator Utility Sensing	0	0									
26P	All Phase Undervoltage	S	S									0
29	<b>Alternative Transfer Modes of Operation</b>											
29G	Selector Switch for Automatic or Non-Automatic Operation (Switch must be Labeled as Non-Automatic)			0		0		0	0	0		
29J	Automatic Transfer Operation with Selectable (Via Programming) Automatic or Non-Automatic Retransfer Operation with Fail-Safe					0		0	0	0		
32	<b>Delayed Transfer Operation Modes</b>											
32A	Time Delay Neutral Adjustable 0 – 120 Seconds			S		S		S	S	S	S	S
32B	Load Voltage Decay Adjustable 2 – 30% Nominal Voltage					0		0	0	0	0	0
32C	In-Phase Monitor Defaults to Load Voltage Decay							0	0	0	0	0
32D	In-Phase Monitor Defaults to Time Delay Neutral							0	0	0	0	0
32E	Delay Transition Timer Adjustable 3 – 60 Seconds						S					
32F	In-Phase Monitor				S							
34	<b>Logic Extender Cable</b>											
34A	48 Inches (1219 mm)					0	0					
34C	96 Inches (2438 mm)					0	0					
34E	144 Inches (3658 mm)					0	0					

① Consult factory for contactor rating availability.

S = Standard, O = Optional

TABLE 44. AUTOMATIC TRANSFER SWITCH FEATURES (CONTINUED)

FEATURE NUMBER	DESCRIPTION	WALL-MOUNT PRODUCT						FLOOR STANDING		CLOSED TRANSITION	SOFT LOAD	
		RLC1	ATV1 ATH1 ATC1	ATV3 ATH3	ATC3 ①	ATV1 ATH1	NTHE NTVE	MTHX MTVX	ATVIMG	BIVIMG	CTVIMG	CTVCMG
		RESIDENTIAL CONTACTOR SWITCH ATC-100 CONTROLLER	LIGHT COMMERCIAL MOLDED CASE DEVICE AND CONTACTOR DESIGN ATC-100 CONTROLLER	MOLDED CASE SWITCH ATC-300 CONTROLLER	CONTACTOR SWITCH ATC-300 CONTROLLER	MOLDED CASE DEVICE ATC-600 IQ TRANSFER	NON-AUTOMATIC TRANSFER SWITCH	MANUAL TRANSFER SWITCH	MAGNUM FIXED AND DRAWOUT MOUNT ATC-600 IQ TRANSFER	MAGNUM BYPASS ISOLATION ATC-600 IQ TRANSFER	MAGNUM FIXED AND DRAWOUT MOUNT ATC-800 CLOSED TRANSITION	MAGNUM LOAD FIXED AND DRAWOUT MOUNT ATC-5000 SOFT LOAD
35A	Pretransfer Signal Contacts 1 Form C			S	S	O			0	0	0	0
36	Load Shed from Emergency					O			0	0	0	0
37	Rated as Suitable for Use as Service Equipment ②③ (Requires 16B or 16N or 16S)											
37A	Without Ground Fault Protection	0		0		0	0		0	0	0	0
37B	With Ground Fault Protection			0		0	0		0	0	0	0
38	Stainless Steel Device Covers											
38A	SS Cover for Device Plate or Service Equipment Disconnect	0	0	0	0	0	0		0	0	0	0
38B	SS Cover for Controller	0	0	0	0	0	0		0	0	0	0
39	Distribution Panel (For 240/120 V, AT_3 Switches Only)											
39A	225 A with (2) 200 A Feeders			0								
39B	300 A with (3) 200 A Feeders			0								
39C	400 A with (4) 200 A Feeders			0								
41	Space Heater with Thermostat											
41A	100 Watts	0	0	0	0	0	0					
41C	400 Watts					0	0	0	0	0	0	0
42	Seismic Zone 4 Certified, CBC, IBC, UBC, BOCA			S	S	S	S	S	S	S	S	S
45	Load Sequencing Contacts											
45A	Load Sequencing Contacts (1)					0			0	0	0	0
45B	Load Sequencing Contacts (2)					0			0	0	0	0
45C	Load Sequencing Contacts (3)					0			0	0	0	0
45D	Load Sequencing Contacts (4)					0			0	0	0	0
45E	Load Sequencing Contacts (5)					0			0	0	0	0
45F	Load Sequencing Contacts (6)					0			0	0	0	0
45G	Load Sequencing Contacts (7)					0			0	0	0	0
45H	Load Sequencing Contacts (8)					0			0	0	0	0
45I	Load Sequencing Contacts (9)					0			0	0	0	0
45J	Load Sequencing Contacts (10)					0			0	0	0	0
47	Closed Transition Operational Modes (User Must Specify Mode)											
47C	Closed Transition In-Phase with Default to Load Voltage Decay										0	0
47D	Closed Transition										0	0
47E	Closed Transition In-Phase with Defaults to Time Delay Neutral										0	0
48	Communications											
48A	IPONI Module					0			0	0	0	0
48D	EPONI Module (10Base-T Only)											
48E	EPONI Module (10Base-T and 10Base-FL)											
48F	MPONI Module (Modbus®)					0			0	0	0	0

① Consult factory for contactor rating availability.

② Ground Fault protection is required for Service Disconnects rated 1000 amperes or more if the electrical service is a solidly grounded wye system of more than 150 volts to ground but not exceeding 600 volts phase to phase.

③ Select 16S for Service Entrance rating on RLC1.

S = Standard, O = Optional

TABLE 44. AUTOMATIC TRANSFER SWITCH FEATURES (CONTINUED)

FEATURE NUMBER	DESCRIPTION	WALL-MOUNT PRODUCT						FLOOR STANDING		CLOSED TRANSITION	SOFT LOAD	
		RLC1	ATV1 ATH1 ATC1	ATV3 ATH3	ATC3 ①	ATV1 ATH1	NTHE NTVE	MTHX MTVX	ATVIMG BIVIMG	CTVIMG	CTVCMG	
		RESIDENTIAL CONTACTOR SWITCH ATC-100 CONTROLLER	LIGHT COMMERCIAL MOLDED CASE DEVICE AND CONTACTOR DESIGN ATC-100 CONTROLLER	MOLDED CASE SWITCH ATC-300 CONTROLLER	CONTACTOR SWITCH ATC-300 CONTROLLER	MOLDED CASE DEVICE ATC-600 IQ TRANSFER	NON-AUTOMATIC TRANSFER SWITCH	MANUAL TRANSFER SWITCH	MAGNUM FIXED AND DRAWOUT MOUNT ATC-600 IQ TRANSFER	MAGNUM BYPASS ISOLATION ATC-600 IQ TRANSFER	MAGNUM FIXED AND DRAWOUT MOUNT ATC-800 CLOSED TRANSITION	MAGNUM LOAD FIXED AND DRAWOUT MOUNT ATC-5000 SOFT LOAD
51	<b>Transient Voltage Surge Protection (Listed Rating is per Phase)</b>											
51D1	50 kA — Clipper Device Connected to Source 1			0	0	0	0	0				
51E1	80 kA — Clipper Device Connected to Source 1			0	0	0	0	0				
51F1	100 kA — Clipper Device Connected to Source 1			0	0	0	0	0				
51G1	50 kA — CHSP Device Connected to Source 1 (240/120 Vac Single-Phase Only)			0	0		0	0				
51H1	75 kA — CHSP Device Connected to Source 1 (240/120 Vac Single-Phase Only)			0	0		0	0				
51J4	Telephone/Modem/DSL (4 Lines Total)			0	0	0	0	0	0	0		
51K4	Cable TV/Satellite Cable/Cable Modem (2 Lines Total)			0	0	0	0	0	0	0		
51M4A	12 Vdc Generator Start Circuit Protection			0	0	0	0	0	0	0		
51M4B	24 Vdc Generator Start Circuit Protection			0	0	0	0	0	0	0	0	
51NA1	100 kA — Surge Device with AdVisor Source1								0	0	0	0
51NS1	100 kA — Surge Device with SuperVisor Source 1								0	0	0	0
51NN1	100 kA — Surge Device with NetVisor Source 1								0	0	0	0
51QA1	160 kA — Surge Device with AdVisor Source 1								0	0	0	0
51QS1	160 kA — Surge Device with SuperVisor Source 1								0	0	0	0
51QN1	160 kA — Surge Device with NetVisor Source 1								0	0	0	0
51SA1	200 kA — Surge Device with AdVisor Source 1								0	0	0	0
51SS1	200 kA — Surge Device w/SuperVisor Source 1								0	0	0	0
51SN1	200 kA — Surge Device w/NetVisor Source 1								0	0	0	0
54A	<b>Front Access Cabinet</b>								0	0	0	0

① Consult factory for contactor rating availability.  
S = Standard, O = Optional

## Transfer Switch — Standard and Optional Features for Cutler-Hammer Transfer Switches

### Timers

#### 1. Time Delay Normal to Emergency (TDNE)

Provides a time delay to allow for the generator to warm up before transferring the load from the Normal Source to the Emergency Source. Timing begins only after the Emergency Source becomes available and deemed good based on the programmable voltage and frequency set points in the controller.

#### 2. Time Delay Engine Start (TDES)

Provides a time delay before initiating the generator start cycle. This is to account for momentary power outages or voltage fluctuations of the Normal Source. Provides a Form "C" contact to the generator starter circuit.

#### 3. Time Delay Emergency to Normal (TDEN)

Provides a time delay of the re-transfer operation to permit stabilization of the Normal Source. Timing begins only after the Normal Source becomes available and deemed good based on the programmable voltage and frequency set points in the controller. This function is fail-safe protected.

#### 4. Time Delay Engine Cooldown (TDEC)

Provides a time delay before initiating the generator stop cycle after the re-transfer operation. This allows the generator to cool down by running unloaded. Timing begins on completion of the re-transfer cycle.

#### 7. Time Delay Emergency Fail (TDEF)

Provides a time delay that prevents a connected emergency source from being declared "Unavailable" based on the customer's set points. This is to account for momentary generator fluctuations. If the Source 2 remains in a failed state, then 0.5 second after the TDEF timer expires the transfer switch will proceed with the programmed sequence for re-transfer if Source 1 is available. This time delay is only implemented when Source 2 is a generator.

#### Note:

This feature is also enabled when large loads cause generator output to drop below customer set points.

### Plant Exerciser

#### 23A. Plant Exerciser With Fail-safe

Provides a means for automatic testing of the engine generator set or standby power system. All programmed time delays in the controller will be performed during plant exerciser operations.

Programmable set points for test intervals are start time, either disabled, daily, 7, 14 or 28 days.

15-minute fixed engine test time.

Test may be performed with or without load transfer. Test may be manually cancelled during the operation. This function is "fail-safe" protected.

#### 23J. Plant Exerciser (PE) With Fail-safe

Provides a means for automatic testing of the engine generator set or standby power system. All programmed time delays in the controller will be performed during the plant exerciser operation.

Programmable set points for test interval are Start Time, either disabled or 7 days, and engine test time.

Test may be performed with or without a load transfer. Test may be manually cancelled during the operation. This is a "fail-safe" operation.

#### 23K. Plant Exerciser With Fail-safe

Provides a means for automatic testing of the engine generator set or standby power system. All programmed time delays in the controller will be performed during plant exerciser operations.

Programmable set points for test intervals are start time, either disabled, daily, 7, 14 or 28 days, engine test time.

Test may be performed with or without load transfer. Test may be manually cancelled during the operation. This function is "fail-safe" protected.

### Source 1 Sensing

#### 26. Source 1 — Monitoring and Protection

Provides Source 1 monitoring and protection functions. If Source 1 fails, then the Automatic Transfer Controller will begin the sequence of operations necessary to transfer the load to Source 2. All **Feature 26** monitoring and protection functions are fail-safe operations.

#### 26H. Three-Phase Rotation Protection

Provides three-phase reversal sensing in order to protect against transferring to an out-of-phase source. The controller will treat the opposite source as unavailable if the sources are out of phase, based on programmable set points in the controller.

#### 26J. All-Phase Undervoltage/Underfrequency Protection

Provides all-phase undervoltage/ underfrequency monitoring and protection based on programmable set points in the controller.

#### 26K. All-Phase Overvoltage/Overfrequency Protection

Provides all-phase overvoltage/overfrequency monitoring and protection based on programmable set points in the controller.

#### 26L. Three-Phase Voltage Unbalance/ Phase Loss

Provides phase loss detection from blown fuses on the Source 1.

#### 26M. Generator Utility Sensing

Allows for the switch to operate with generators that have internal utility sensing. This option comes as a kit that needs to be field installed.

### Source 2 Sensing

#### 5. Source 2 — Monitoring and Protection

Provides monitoring and protection based on the Source 2 voltage and/or frequency set points. All **Feature 5** monitoring and protection functions are fail-safe operations.

#### 5J. All-Phase Undervoltage/Underfrequency Protection

Provides Undervoltage/Underfrequency monitoring and protection based on programmable set points in the controller.

#### 5K. All-Phase Overvoltage/Overfrequency Protection

Provides Over/Voltage/Overfrequency monitoring and protection based on programmable set points in the controller.

#### 5H. Three-Phase Rotation Protection

Provides three-phase reversal sensing in order to protect against transferring to an out-of-phase source. The controller will treat the opposite source as unavailable if the sources are out of phase, based on programmable set points in the controller.

#### 5L. Three-Phase Voltage Unbalance/Phase Loss

Provides phase loss detection from blown fuses on the Source 2 supply circuit.

### Manual Controls

#### 6B. Test Operators

Automatic Transfer Switches are provided with a Test Pushbutton that simulates a loss of the Source 1 as standard. All programmed time delays (TDNE, TDEN, etc.) will be performed as part of the Test. Engine run time of the Test is equal to the Plant Exerciser programmed set point. All Tests are fail-safe protected.

#### 6H. 4-Position Test Selector Switch (FPSS)

Provides a 4-position, maintained contact selector switch marked "Auto," "Test," "Engine Start," and "Off." The FPSS is fail-safe protected, except for the "Off Position." Transfer Switch operation is determined by the switch position. Transfer Switch operations are as follows:

"Auto" — Automatic operation mode.

"Test" — A Load test is performed until the switch is moved to another position.

"Engine Start" — A No-Load test is performed until the switch is moved to another position.

"Off" — The Automatic Transfer Controller and engine start contact are disabled. A white pilot light is provided to indicate that the FPSS is in the "Off" position.

##### Note:

This option will force the switch to be marked as non-automatic based on UL 1008.

#### 8. Time Delay Bypass Pushbutton

Provides a momentary contact pushbutton to bypass the TDNE (**Feature 1**) and/or TDEN (**Feature 2**) time delays. The Time Delay Bypass Pushbutton contact, when closed, will reduce any or all of the programmed time delay to zero. Must be executed when TDNE or TDEN timer is displayed on the controller.

#### 8C. Bypass Time Delay Emergency to Normal (TDEN)

#### 8D. Bypass Time Delay Normal to Emergency (TDNE)

#### 9B. Maintenance Selector Switch (MSS)

Provides a 2-position, maintained contact selector switch marked "Operate" and "Disable." When the MSS is placed in the "Disable" position, the controller logic will be disconnected from the transfer motor circuit. The MSS is placed in the "Operate" position for normal automatic operation.

#### 29. Transfer Operation Modes

Provides standard or optional transfer modes, mode selection devices and operational methods for Transfer Switches.

##### 29G. Automatic/Manual Operation With Selector Switch

Provides 2-position selector switch (labeled Auto/Manual) that permits selection of the Automatic or Manual transfer. When in the "Auto" position, the transfer switch operates with fully automatic transfer, re-transfer and generator startup and shutdown operations. When in the "Manual" position, manual operation is required to initiate the generator startup or re-transfer with generator shutdown operations.

##### Note:

Transfer switches with **Feature 29G** must be labeled as Non-Automatic Transfer Switch equipment.

##### 29J. Automatic Transfer or Automatic Transfer With Non-Automatic Re-transfer Operation

Provides a field-selectable programmable set point that permits the transfer switch to operate in one of the following 2 transfer modes (A or B).

- A. Fully automatic operation.
- B. Automatic engine/generator startup and automatic transfer operation from Source 1 to Source 2. Manual pushbutton operation is required to initiate the re-transfer operation and engine/generator shutdown. The pushbutton for manual re-transfer operation is included. This is fail-safe protected.

#### 10. Preferred Source Selector

Provides a means to designate either Source 1 or Source 2 as the "Preferred" source. The "Preferred" source is the source that the transfer switch will connect the load to if it is available.

##### Note:

This is a programmable software feature not an actual switch.

#### 10B. Preferred Source Selector

Provides a programmable source selector for use on systems comprised of dual utility or utility and engine/ generator power sources.

#### 10D. Preferred Source Selector

Provides a programmable source selector for use on systems comprised of dual engine/generator power sources. (Dual engine starting circuits are provided.)

#### Indications/and Status Display

##### 12C. Source 1 — Load Connected

Provides a green indication that indicates the load is connected to Source 1 when lit.

##### 12D. Source 2 — Load Connected

Provides a red indication that indicates the load is connected to Source 2 when lit.

##### 12G. Source 1 — Present

Provides a white or amber indication "Depending on the Controller" that Source 1 has power, however this does not indicate whether Source 1 is acceptable.

##### 12H. Source 2 — Present

Provides an amber indication that Source 2 has power, however this does not indicate whether Source 2 is acceptable.

#### Overcurrent Trip Indication

Available only with Integral Overcurrent Protection (**Feature 16**). (Shown on Automatic Transfer Controller Display.)

##### 12L. Source 1 Trip Indication

The Automatic Transfer Controller display will read "Lockout" if the Source 1 circuit breaker is in the "tripped" position.

##### 12M. Source 2 Trip Indication

The Automatic Transfer Controller display will read "Lockout" if the Source 2 circuit breaker is in the "tripped" position.

#### Customer Outputs

##### 14. Relay Auxiliary Contacts

###### 14C. Source 1 Present

Provides 4 Form "C" relay auxiliary contacts. The relay is energized when Source 1 is Present.

###### 14D. Source 2 Present

Provides 4 Form "C" relay auxiliary contacts. The relay is energized when Source 2 is Present.

###### 14E. Source 1 Available

Provides 1 Form "C" relay auxiliary contact. The relay is energized when Source 1 is available and within the controller's programmable set points.

###### 14F. Source 2 Available

Provides 1 Form "C" relay auxiliary contact. The relay is energized when Source 2 is available and within the controller's programmable set points.

###### 14G. Source 1 Present

Provides 2 Form "C" relay auxiliary contacts. The relay is energized when Source 1 is available and within the controller's programmable set points.

###### 14H. Source 2 Present

Provides 2 Form "C" relay auxiliary contacts. The relay is energized when Source 2 is available and within the controller's programmable set points.

### 15. Switch Position Indication Contact

Provides a contact that indicates if the power switching device is in the “open” or “closed” position.

### 15E. Source 1 Position Indication Contact

Provides 1 Form “C” contact that indicates the position of the Source 1 power switching device.

### 15F. Source 2 Position Indication Contact

Provides 1 Form “C” contact that indicates the position of the Source 2 power-switching device.

### 15M. Source 2 Load Shed Contacts

Provides 4 Form “C” contacts to initiate a load circuit disconnect while on Source 2. This gives the user the capability of selectively choosing not to run certain loads while on Source 2.

### 35A. Pre-Transfer Signal With 1 Form “C” Contact

Provides a signal prior to the transferring of the load. Will not transfer until the programmable delay set point in the controller is reached. If both sources are not available, this option will ignore the time delay set in the controller.

## Customer Inputs

### 26D. Go to Emergency (Source 2)

Provides the capability for an external contact closure to initiate a transfer to the Source 2 power source. This includes starting the generator, performing the programmed time delays and the transfer operation. Re-transfer will occur when the external contact is opened. This is a fail-safe function.

### 36. Load Shed From Emergency

Provides the capability for an external NC contact to initiate a load circuit disconnection from the Source 2 power source. If the load circuit is connected to Source 2 and the contact is opened, then a re-transfer to Source 1 is completed if Source 1 is available. If Source 1 is not available, then the transfer switch will transfer to neutral. If the load circuit is connected to Source 1 and the contact is open, then a transfer Source 2 is prohibited.

## 16. Integral Overcurrent Protection

Provides thermal-magnetic overcurrent protection integral to the power switching device(s). All **Feature 16** options include a “Lock-out” function. If the power switching breaker trips on an overcurrent condition, then “Lockout” is displayed on the Automatic Transfer Controller display and automatic operation is prevented until the appropriate source is manually reset. On non-automatic switches, a blue light is supplied to indicate the “lockout.”

### 16B. Integral Overcurrent Protection on Both Power Source Switching Devices

Provides integral overcurrent protection on both Source 1 and Source 2 power switching devices.

### 16E. Integral Overcurrent Protection on the Source 2 Power Switching Device

Provides integral overcurrent protection on the Source 2 power switching device.

### 16N. Integral Overcurrent Protection on the Source 1 Power Switching Device

Provides integral overcurrent protection on the Source 1 power switching device.

### 16S. External Overcurrent Protection on the Source 1 Power Switching Device

Provides overcurrent protection on the Source 1 power switching device.

## 18. Metering

The microprocessor-based multi-function monitoring and display features the latest technological advances in metering and communications capabilities.

Available with an optional communications interface. (See **Feature 48** — Communications for available communication modules.)

**Feature 18** metering options include all required external devices (CTs etc.) for a fully functioning metering system.

## IQ Analyzer

The IQ Analyzer is an rms sensing, multi-function microprocessor-based monitoring and display device with waveform capture that provides simultaneous monitoring of current, voltage, frequency, power (real, reactive and apparent), energy (real, reactive and apparent), demand (forward, reverse and net), harmonics (magnitude and phase angle), power factor and percent THD (current and voltage).

### 18O. IQ Analyzer — Source 1 Line Side Metering

Provides an IQ Analyzer for monitoring the Source 1 line side circuit.

### 18P. IQ Analyzer — Source 2 Line Side Metering

Provides an IQ Analyzer for monitoring the Source 2 line side circuit.

### 18Q. IQ Analyzer With Selector Switch for Source 1 or Source 2 Line Side Metering

Provides an IQ Analyzer with a Source selector switch for monitoring the Source 1 or Source 2 line side circuit.

## IQ DP-4000

The IQ DP-4000 is an rms sensing, multi-function microprocessor-based monitoring and display device that provides simultaneous monitoring of current, voltage, frequency, power (real, reactive and apparent), energy (real, reactive and apparent), power factor and percent THD (current and voltage).

### 18R. IQ DP-4000 — Source 1 Line Side Metering

Provides an IQ DP-4000 for monitoring the Source 1 line side circuit.

### 18S. IQ DP-4000 — Source 2 Line Side Metering

Provides an IQ DP-4000 for monitoring the Source 2 line side circuit.

### 18T. IQ DP-4000 With Selector Switch for Source 1 or Source 2 Line Side Metering

Provides an IQ DP-4000 with a Source selector switch for monitoring the Source 1 or Source 2 line side circuit.

### 18U. IQ DP-4000 — Load Side Metering

Provides an IQ DP-4000 for monitoring the load side circuit.

### 18V. IQ Analyzer — Load Side Metering

Provides an IQ Analyzer for monitoring the load side circuit.

### 18W. Ammeter Side Metering

Provides an ammeter for monitoring the load side circuit.

## 20A. Rear Bus Provisions

Provides Source 1, Source 2 and Load Circuit rear accessible bus stabs with provision for busbar connection. Cutler-Hammer Transfer Switches are provided with either front or rear (dependant on switch type) connected solderless screw-type terminals for power cable connection as standard.

## 21A. Optional Power Cable Connection Terminals

Cutler-Hammer Transfer Switches are provided as standard with Source 1, Source 2 and Load Circuit solderless screw-type terminals for power cable connection. Alternate terminal wire sizes, and compression lug provisions may be available dependant on transfer switch type and ampere rating.

## 32. Delayed Transition Transfer Modes for Open Transition Transfer Switches

Provides delayed transition transfer modes for an open transition transfer switch. Often used in systems with inductive loads, a delayed transition transfer switch may prevent or reduce inrush currents due to out of phase switching of inductive loads.

### 32A. Time Delay Neutral

Provides a time delay in the neutral position during the transfer and re-transfer operations during which both Source 1 and Source 2 are disconnected from the load circuit. This allows inductive loads time to reach a safe voltage and eliminate back EMF. The time delay is programmable and is the same for both transfer and re-transfer operations. This is a passive feature which requires the consulting Eng./ installer to determine the settings based on how the user will operate the facility. Adjustable 0 – 120 seconds.

### 32B. Load Voltage Decay

Provides load voltage measurement to sense back EMF that is generated when the transfer switch is the neutral position. It provides a delay in transfer in either direction if an unacceptable level is sensed as established by a programmed set point. This is an active feature that adapts to how the facility is operating in order to minimize neutral position wait time, but ensure safety. Adjustable 2 – 30% of nominal voltage.

### 32C. In-Phase Transition With Default to Load Voltage Decay

Provides In-Phase transition, which is a feature that will permit a transfer or re-transfer between 2 available sources that have a phase angle difference near zero. The In-Phase transition feature includes permissible frequency difference and synchronization time set points. In the event Source 1 and Source 2 fail to synchronize within the permitted frequency difference and time, then the controller defaults to the Load Voltage Decay operation as described in **Feature 32B**. Adjustable Frequency Difference 0.0 – 3.0 Hz. Adjustable Synchronization Time Allowance 1 – 60 minutes.

### 32D. In-Phase Transition With Default to Time Delay Neutral

Provides In-Phase transition, which is a feature that will permit a transfer or re-transfer only between 2 available sources that have a phase angle difference near zero. The In-Phase transition feature includes permissible frequency difference and synchronization time set points. In the event Source 1 and Source 2 fail to synchronize within the permitted frequency difference and time then the controller defaults to the Time Delay Neutral operation as described in **Feature 32A**. Adjustable Frequency Difference 0.0 – 3.0 Hz. Adjustable Synchronization Time Allowance 1 – 60 minutes.

### 32F. In-Phase Transition

Provides In-Phase transition, this feature will permit a transfer or re-transfer between 2 available sources that have a phase angle difference of 8 degrees or less. The In-Phase transition feature includes permissible frequency difference and synchronization time set points. In the event Source 1 and Source 2 fail to synchronize within the permitted frequency difference and time, the Alarm relay will energize and “Failed to Sync” will be displayed on Line 1 of the controller. After resetting the alarm, another in-phase transition may be attempted or a non-synchronized transfer may be initiated by failing the connected source. The adjustable frequency difference is 0.0 to 3.0 Hz. If the synchronization does not occur within a specified amount of time, the Alarm relay will energize and the failure will be logged into the Transfer History as either “Sync Fail - Freq” or “Sync Fail - Phase” depending on whether the frequency difference or the phase difference was excessive.

### 47. Transfer Modes for Closed Transition Transfer Switches

Provides available transition transfer modes for a closed transition transfer switch. Closed Transition is a “make before break” transfer and re-transfer scheme that will parallel (a maximum of 100 ms) Source 1 and Source 2 providing a seamless transfer when both sources are available. The closed transition feature includes permissible voltage difference frequency difference and synchronization time allowance set points. The phase angle difference between the 2 sources must be near zero for a permitted transfer. These are all programmable set points in the controller.

### 47C. Closed Transition With Default to In-Phase Transition With Default to Load Voltage Decay

Provides a closed transition transfer as the primary transfer mode. In the event Source 1 and Source 2 fail to synchronize within the permitted voltage difference, frequency difference, phase angle difference and time, then the controller defaults to the In-Phase Transition With Default to Load Voltage Decay operations as described in **Features 32C and 32B**. Adjustable Frequency Difference 0.0 – 0.3 Hz. Adjustable Voltage Difference 1 – 5 percent V. Adjustable synchronization Time Allowance 1 – 60 minutes.

### 47D. Closed Transition

Provides a closed transition transfer as the primary transfer mode. Only under a fail-safe condition (i.e., loss of the connected source) will the controller transfer to the alternate source using the Load Voltage Decay operation as described in **Feature 32B**. Adjustable Frequency Difference 0.0 – 0.3 Hz. Adjustable Voltage Difference 1 – 5% V.

### 47E. Closed Transition With Default to In-Phase Transition With Default to Time Delay Neutral

Provides a closed transition transfer as the primary transfer mode. In the event Source 1 and Source 2 fail to synchronize within the permitted voltage difference, frequency difference, phase angle difference and time, then the controller defaults to the In-Phase Transition With Default to Time Delay Neutral operation as described in **Features 32D and 32A**. Adjustable Frequency Difference 0.0 – 0.3 Hz. Adjustable Voltage Difference 1 – 5 percent V. Adjustable synchronization Time Allowance 1 – 60 minutes.

### Logic Extender Cable

#### 34A. 48 Inches (1219 mm)

Provides logic extension cable with connectors.

#### 34C. 96 Inches (2438 mm)

Provides logic extension cable with connectors.

#### 34E. 144 Inches (3658 mm)

Provides logic extension cable with connectors.

### 37. Service Equipment Rated Transfer Switch

Provides the label “Suitable for use as Service Equipment” and the features necessary to meet the requirements for the label. Includes service disconnect with visible indication and neutral assembly with removable link. **Feature 16B** or **16N** must be selected separately.

#### 37A. Service Equipment Rated Transfer Switch Without Ground Fault Protection

Provides Service Equipment rating for an application that does not require ground fault protection.

#### 37B. Service Equipment Rated Transfer Switch With Ground Fault Protection

Provides Service Equipment rating for an application that requires ground fault protection.

### 38. Stainless Steel Cover

Provides protection for the controller.

### 39. Distribution Panel

The Distribution Panel feature utilizes a Panelboard design with bolt-on circuit breakers. Bolt-on breakers are designed to hold up to the changes in temperature and humidity that an industrial application calls for. (240/120 Vac single-phase systems only.)

#### 39A. 225 A With (2) 200 A Feeders

#### 39B. 300 A With (3) 200 A Feeders

#### 39C. 400 A With (4) 200 A Feeders

#### 41. Space Heater With Thermostat

Provides a space heater and adjustable thermostat. External control power is not required. Availability is dependent on transfer switch type.

##### 41A. Space Heater With Thermostat — 100 Watt

Provides 100-watt space heater with an adjustable thermostat.

##### 41C. Space Heater With Thermostat — 400 Watt

Provides 400-watt space heater with an adjustable thermostat.

#### 42. Seismic Certification

Provides a Seismic certified Transfer Switch with certificate for application is Seismic Zone 4 under the California Building Code (CBC), the Uniform Building Code (UBC) and BOCA, and International Building Code (IBC).

#### 45. Load Sequencing Capability

Provides the capability for sequential closure of up to 10 addressable relays after a transfer. Each Addressable Relay provides (1) Form "C" contact. A single adjustable time delay between each of the relay closures is provided. Operates via a sub-network. Adjustable 1 – 120 seconds.

##### 45A. Load Sequencing Contact

Provides (1) addressable relay.

##### 45B. Load Sequencing Contact

Provides (2) addressable relays.

##### 45C. Load Sequencing Contact

Provides (3) addressable relays.

##### 45D. Load Sequencing Contact

Provides (4) addressable relays.

##### 45E. Load Sequencing Contact

Provides (5) addressable relays.

##### 45F. Load Sequencing Contact

Provides (6) addressable relays.

##### 45G. Load Sequencing Contact

Provides (7) addressable relays.

##### 45H. Load Sequencing Contact

Provides (8) addressable relays.

##### 45I. Load Sequencing Contact

Provides (9) addressable relays.

##### 45J. Load Sequencing Contact

Provides (10) addressable relays.

#### 48. Communication Modules

Provides communications modules for the ATC-600 and ATC-800 (Closed Transition) transfer switch controllers. A separately mounted communications module will enable the automatic transfer controller to be remotely monitored controlled and programmed via a network.

##### 48A. Communications Module — IPONI

Provides INCOMM protocol communications modules.

##### 48D. Communications Module — EPONI

Provides INCOMM protocol via Ethernet communications module. (10Base-T only.)

##### 48E. Communications Module — EPONI

Provides INCOMM protocol via Ethernet communications module. (10Base-T and 10Base-FL.)

#### 48F. Communications Module — MPONI

Provides Modbus RTU protocol via communications module.

#### Transient Voltage Surge Protection

There are 3 surge options to choose from. They are CHSP, CVL, CPS. In addition there are 2 generator start circuits protectors. The listed rating is per Phase and availability is dependent on transfer switch type.

#### Generator Start Circuit Protection

**51M4A.** 12 Vdc Engine control Start Circuit Protection.

**51M4B.** 24 Vdc Engine control Start Circuit Protection.

**CHSP Surge Suppression** is designed for single-phase loads with a maximum capacity of 70 k per phase. Also available for telephone and cable applications.

**51G1.** 50 kA — Connected to Source 1. (240/120 Vac single-phase systems only.)

**51H1.** 75 kA — Connected to Source 1. (240/120 Vac single-phase systems only.)

**51J4.** Telephone/Modem/DSL (4 Lines Total.)

**51K1.** Cable TV/Satellite Cable/Cable Modem.

**CVL** is a Clipper commercial grade protection and EMI/RFI filter. Comes standard with phase indicator lights to monitor component status, Form "C" alarm contacts and an audible alarm. Surge range 50 to 100 k per phase.

**51D1.** 50 kA Connected to Source 1.

**51E1.** 80 kA Connected to Source 1.

**51F1.** 100 kA Connected to Source 1 (2 Lines Total.)

**CPS** is a Clipper commercial grade protection and EMI/RFI filter. Available range is 100 to 200 k phase-to-phase Industrial grade surge protection.

**CPS AdVisor** has phase status indicator lights to indicate protection availability and a Form "C" alarm contact and audible alarm.

#### Field Kits Available

Replacement controllers as, well as field upgrade kits, are available and identified by style numbers.

Controller Field Kits — **8160A00G X X**

Consult factory for correct selection for group number.

Option Field Kits — **8160A X X G X X**

Consult factory for correct selection of style number.

**CPS SuperVisor** has a voltage meter and transient counter, with event capture phase status indicator lights to indicate protection availability, and a Form "C" alarm contact and audible alarm.

**CPS NetVisor** has voltage meter and transient counter, with event capture, life remaining and %THD communication over Modbus and Ethernet. Phase status indicator lights to indicate protection availability. Form "C" alarm contact and audible alarm.

**51NA1.** 100 kA — Surge Device with AdVisor.

**51NS1.** 100 kA — Surge Device with SuperVisor Source 1.

**51NN1.** 100 kA — Surge Device with NetVisor Source 1.

**51QA1.** 160 kA — Surge Device with AdVisor Source 1.

**51QS1.** 160 kA — Surge Device with SuperVisor Source 1.

**51QN1.** 160 kA — Surge Device with NetVisor Source 1.

**51SA1.** 200 kA — Surge Device with AdVisor Source 1.

**51SS1.** 200 kA — Surge Device with SuperVisor Source 1.

**51SN1.** 200 kA — Surge Device with NetVisor Source 1.

#### 54. Front Access

**54A.** Front Access Cabinet available for all Magnum products. This option will add an additional pull section mounted on the side of the switch.

## Glossary

With respect to their use in this document and as they relate to switch operation, the following terminology is defined:

**Available** — A source is defined as “available” when it is within its undervoltage/overvoltage/underfrequency/overfrequency (if applicable) set point ranges for the nominal voltage and frequency setting.

**Fail-safe** — A feature that prevents disconnection from the only available source and will also force a transfer or re-transfer operation to the only available source.

**Re-Transfer** — “Re-Transfer” is defined as a change of the load connection from the secondary to primary source.

**Source 1** — is the primary source or Normal Source or Normal Power Source or Normal. (Except when Source 2 has been designated the “Preferred Source.”)

**Source 2** — is the secondary source or Emergency Source or Emergency Power Source or Emergency or Standby or Backup source. (Except when Source 2 has been designated the “Preferred Source.”)

**Source 1 — Failed or Fails** — Source 1 is defined as “failed” when it is outside of its undervoltage or overvoltage or underfrequency or overfrequency (if applicable) set point ranges for the nominal voltage and frequency setting.

**Source 2 — Failed or Fails** — Source 2 is defined as “failed” when it is outside of its undervoltage or overvoltage or underfrequency or overfrequency (if applicable) set point ranges for the nominal voltage and frequency setting for a time exceeding 0.5 seconds after the Time Delay Emergency Fail (TDEF) time delay expires.

**Transfer** — “Transfer” is defined as a change of the load connection from the primary to secondary source except when specifically used as “Transfer to Neutral.”

**Transfer to Neutral** — “Transfer to Neutral” is defined as when the load circuits are disconnected from both Source 1 and Source 2.

Metering



**IQ Analyzer**

Highly accurate source or load metering can be provided for advanced energy management and power quality analysis. Meeting the stringent ANSI C12.16 Class 10 accuracy requirement, Eaton's IQ Analyzer meter can measure parameters including voltage, current, power (watts, vars and VA), energy, frequency, demand, power factor, %THD (voltage and current), K factor, CBEMA derating factor and crest factor. IQ Analyzer can also communicate with Eaton's industry accepted IMPACC and PowerNet™ Power Management Systems. (See Eaton TD 17530, available on line, for more information.)



**Protective Relay**

For paralleling (including soft loading/unloading) applications, utility grade protective relaying is optional, and offered when utility interconnection standard requires additional protection on top of that provided by ATC-5000 controller. The following protective relays can be included in Eaton Soft Load ATS:

- Beckwith M-3410A — See **Appendix B** for details.
- Beckwith M-3520.
- Schweitzer SEL-351.
- Schweitzer SEL-547.
- Basler BE1-951.
- Basler BE1-IPS100.

All above protective relays provide protection necessary to satisfy IEEE P1547 standard "IEEE Standard for Interconnecting Distributed Resources with Electric Power Systems." See **Table 45**.

**TABLE 45. PROTECTIVE RELAYS**

ANSI/IEEE NUMBER	FUNCTION	UTILITY INTERTIE PROTECTION							
		ATC-5000	EATON DIGITRIP (OPTIONAL)	BECKWITH M-3410A (OPTIONAL)	BECKWITH M-3520 (OPTIONAL)	SCHWEITZER SEL-547 (OPTIONAL)	SCHWEITZER SEL-351 (OPTIONAL)	BASLER BE1-951 (OPTIONAL)	BASLER BE1-IPS100 (OPTIONAL)
21	Phase Distance				0				
24	Overexcitation V/Hz							S	S
25	Synchronizer	S							
	Synch Check			S	S	S	S	S	S
27	Undervoltage	S ①②		S	S	S	S	S	S
27G	Ground Undervoltage			S	0				
32	Reverse/Forward Power	S ①		S	S	S	S	S	S
40	Loss-of-Field			S					
46	Negative Sequence Overcurrent	S ①		S	S				
47	Negative Sequence Overvoltage			S	S	S		S	S
50	Instantaneous Phase Overcurrent	S ①	S ①②		S		S	S	S
50N	Instantaneous Ground Overcurrent		0 ①②		S		S	S	S
51	ac Time Overcurrent	S ①②	S ①②				S	S	S
51N	ac Time Ground Overcurrent		0 ①②	S	S		S	S	S
51V	Voltage Restrained Overcurrent			S	S				S
59	Overvoltage	S ①②		S	S	S	S	S	S
59G	Ground Overvoltage			S	0				S
59I	Peak Overvoltage			S	0				
60FL	VT Fuse-Loss Detection			S	S			S	S
62	General Purpose Timers							S	
67	Phase Directional Overcurrent				S		S		S
67N	Residual Directional Overcurrent				0		S		
72	Phase/Vector Shift	S ②							
79	Reconnect Enable Time Delay			S	S		S		S
81 O/U	Over/Underfrequency	S ①②		S	S	S	S	S	S
81R	Rate of Change of Frequency				0				S

① Generator Protective Feature S = Standard Function; O = Optional Function.  
 ② Utility Protective Feature.

## Transient Voltage Surge Suppression

Eaton's Clipper Power System —Visor™ series transient voltage surge suppression (TVSS) components can be integrated into any closed transition soft load switch. Surge current ratings 100 kA, 160 kA and 200 kA per phase provide a range of cost effective facility-wide protection solutions. Status indication on each phase is standard with any TVSS option. Metering and communication capabilities are also available. See Appendix C for details.

## Communications

Optional communication capability via Communication Gateway is available allowing remote data access, control, programming, system interface and dispatch.

## System Interface

A system control panel provides user-friendly interface to the closed transition soft load controller, allowing operators to easily monitor the switching devices position and manually test generator and the system operations.

## Switching Devices Status Lights

- Source 1 Open (Green).
- Source 1 Closed (Red).
- Source 1 Trip (Amber).
- Source 2 Open (Green).
- Source 2 Closed (Red).
- Source 2 Trip (Amber).

## Front Panel Control Switches and Lights

The combination of the following pilot devices can be implemented on the unit:

- AUTO/TEST Switch.
- SYSTEM TEST Switch.
- TEST MODE Switch.
- ALARM SILENCE Switch.
- READY FOR OPERATION Lamp (White) — Verifies the ATC-5000 status.

## Optional Intergral Overcurrent Protection Capability

For service entrance applications, Digitrip microprocessor-based trip units can be integrated into the power switching devices. This eliminates the need for the separate upstream protective device, saving installation cost and space. Available with various combinations of Long, Short, Instantaneous and Ground Fault Protection, Digitrips can communicate with Eaton's IMPACC and PowerNet™ Power Management Systems.

## Optional On-board 24 Vdc Power Supply

On-board 24 Vdc power supply circuit, consisting of two (2) 12 Vdc gel-cell UPS type batteries and battery charger, is available on the unit to provide dc control power to soft load transfer switch components. Engine battery can be connected in the "best battery" circuit as well, further improving the system's reliability.

## Transfer Switch — Optional Components

**TABLE 46. OPTIONS**

<b>DESCRIPTION</b>	
<b>Service Entrance Rating</b>	
16N	Overcurrent Protection — Normal
16E	Overcurrent Protection — Emergency
16B	Overcurrent Protection — Both
37A	Service Entrance
37B	Service Entrance with Ground Fault
<b>Metering</b>	
180	IQ Analyzer — Normal
18P	IQ Analyzer — Emergency
18Q	IQ Analyzer — N/E Selectable
18U	IQ Analyzer — Load
<b>Plant Exerciser</b>	
23J	Automatic 24 Hours/7 Days Selectable Load/No Load
<b>Expanded Controller I/O</b>	
25A	Additional Discrete and Analog I/O for Genset Control and Monitoring
<b>Space Heater and Thermostat</b>	
41C	400 W Heater with Thermostat
<b>Surge Protection</b>	
51M4B	Engine Control (24 Vdc) Surge Device
51NA1	100 kA Surge Device with AdVisor Source 1
51NS1	100 kA Surge Device with SuperVisor Source 1
51NN1	100 kA Surge Device with NetVisor Source 1
51QA1	160 kA Surge Device with AdVisor Source 1
51QS1	160 kA Surge Device with SuperVisor Source 1
51QN1	160 kA Surge Device with NetVisor Source 1
51SA1	200 kA Surge Device with AdVisor Source 1
51SS1	200 kA Surge Device with SuperVisor Source 1
51SN1	200 kA Surge Device with NetVisor Source 1
<b>On-Board 24 Vdc Power Supply</b>	
24C	Battery Charger and Gell-Cell Batteries
<b>Protective Devices</b>	
53A	Beckwith M-3410A
53B	Schweitzer SEL-547
53C	Basler BE1-951
53D	Beckwith M-3520
53E	Schweitzer SEL-351
53F	Basler BE1-IPS100
<b>Communication</b>	
54B	External Communication Gateway
54C	Serial Modbus Over Ethernet
<b>Field Start-up</b>	
56A	2-Day Start-up (Includes 1 Day for Travel)

## Appendix A

**TABLE 47. KW TO AMPERE CONVERSION CHART**

**THREE-PHASE AMPERE TABLE AT COMMON LINE-TO-LINE VOLTAGE**

<b>KW ①</b>	<b>200 V</b>	<b>208 V</b>	<b>220 V</b>	<b>230 V</b>	<b>240 V</b>	<b>380 V</b>	<b>400 V</b>	<b>415 V</b>	<b>460 V</b>	<b>480 V</b>	<b>600 V</b>
5.0	18	17	16	16	15	9	9	9	8	8	6
7.5	27	26	25	24	23	14	13	13	12	11	9
10.0	36	34	33	31	30	19	18	17	16	15	12
15.0	54	52	49	47	45	28	27	26	24	23	18
20.0	72	69	66	63	60	38	36	35	31	30	24
25.0	90	87	82	78	75	47	45	43	39	38	30
30.0	108	104	98	94	90	57	54	52	47	45	36
40.0	144	139	131	126	120	76	72	70	63	60	48
50.0	180	173	164	157	150	95	90	87	78	75	60
60.0	217	208	197	188	180	114	108	104	94	90	72
75.0	271	260	246	235	226	142	135	130	118	113	90
80.0	289	278	262	251	241	152	144	139	126	120	90
100.0	361	347	328	314	301	190	180	174	157	150	120
125.0	451	434	410	392	376	237	226	217	196	188	150
150.0	541	520	492	471	451	285	271	261	235	226	180
175.0	631	607	574	549	526	332	316	304	275	263	210
200.0	722	694	656	628	601	380	361	348	314	301	241
250.0	902	867	820	784	752	475	451	435	392	376	301
300.0	1083	1041	984	941	902	570	541	522	471	451	361
350.0	1263	1214	1148	1098	1052	665	631	609	549	526	421
400.0	1443	1388	1312	1255	1203	760	722	696	628	601	481
500.0	1804	1735	1640	1569	1504	950	902	870	784	752	601
600.0	2165	2082	1968	1883	1804	1140	1083	1043	941	902	722
700.0	2526	2429	2296	2197	2105	1329	1263	1217	1098	1052	842
800.0	2887	2776	2624	2510	2406	1519	1443	1391	1255	1203	962
900.0	3248	3123	2952	2824	2706	1709	1624	1565	1412	1353	1083
1000.0	3609	3470	3280	3138	3007	1899	1804	1739	1569	1503	1203

① At 0.8 Power Factor.

## Appendix B M-3410A Inter-Tie Protective Relay

Refer to the appropriate table to make protective relaying changes.

**TABLE 48. M-3410A INTER-TIE PROTECTIVE RELAY SET POINTS**

DEVICE NUMBER	FUNCTION	SET POINT RANGES	INCREMENT	ACCURACY
<b>Sync Check</b>				
25	Phase Angle Window	0° to 90°	1°	±1°
	Upper Voltage Limit	100.0 to 120.0% ①	0.1%	±0.5 V or ±0.5%
	Lower Voltage Limit	70.0 to 100.0% ①	0.1%	±0.5 V or ±0.5%
	Delta Voltage Limit	1.0 to 50.0% ①	0.1%	±0.5 V
	Delta Frequency Limit	0.001 to 0.500 Hz	0.001 Hz	±0.001 Hz or 5%
	Sync Check Time Delay	1 to 8160 Cycles	1 Cycle	—
	Dead Voltage Limit	0.0 to 50.0% ①	0.1%	±0.5 V or ±0.5%
	Dead Time Delay	1 to 8160 Cycles	1 Cycle	±2 Cycles
Sync Check may be operated as a stand-alone function or supervised by 79 (reconnect). Various combinations of input supervised hot/dead closing schemes may be selected. This function can only be enabled in line-to-line VT configuration and when function 27G and 59G are not enabled.				
<b>Phase Undervoltage</b>				
27	Pickup #1, #2	4 to 100% ①	0.1%	±0.5 V or ±0.5%
	Time Delay #1, #2	1 to 8160 Cycles	1 Cycle	±2 Cycles ②
<b>Ground Undervoltage</b>				
27G	Pickup	4 to 100% ③	1.0%	±0.5 V or ±0.5%
	Time Delay	1 to 8160 Cycles	1 Cycle	±2 Cycles
This function can only be enabled when the relay is configured in line-to-line VT and the 25 function is not enabled.				
<b>Directional Power</b>				
32	Pickup #1, #2	-3.00 to +3.00 PU	0.01 PU	±0.02 PU or 2% ④
	Time Delay #1, #2	1 to 8160 Cycles	1 Cycle	±2 Cycles
The per-unit pickup is based on nominal VT secondary voltage and nominal CT secondary current settings for currents less than 14 A (2.8 A). This function can be selected as overpower or underpower in the forward direction (positive setting). This function can also be selected for single-phase detection for line-to-ground VT. Minimum sensitivity of 100 mA for 5 A CT (real component of current).				
<b>Loss-of-Field (Dual-Zone Offset-MHO Characteristic)</b>				
40	Circle Diameter #1, #2	0.01 to 3.00	0.01 PU	±0.01 PU or ±5% ④
	Offset #1, #2	-2.0 to 2.0	0.01 PU	±0.01 PU or ±5% ④
	Time Delay #1, #2	1 to 8160 Cycles	1 Cycle	±2 Cycles
27	Voltage Control (Positive Sequence)	4 to 100% ①	0.1%	±0.5 V or ±0.5%
	Directional Element	Fixed at -13°	—	—
<b>Negative Sequence Overcurrent</b>				
46	<b>Definite Time</b>			
	Pickup	3% to 300% ⑤	1%	±0.1 A or ±5% ⑥ (±0.02 A or ±5%)
	Time Delay	1 to 8160 Cycles	1 Cycle	±2 Cycles
	<b>Inverse Time</b>			
	Pickup	3% to 100% ⑤	0.1%	±0.1 A or ±3% ⑥ (±0.02 A or ±3%)
	Characteristic Curves	Definite Time/Inverse Time/Very Inverse/Extremely Inverse/IEC/I <sup>2</sup> t = K		
	Time Dial Setting	0.5 to 11.0	0.1	±3 Cycles or ±10% ⑥
		0.05 to 1.10 (IEC)	0.01	—
		1 to 95 (I <sup>2</sup> t = K)	1	—
	<b>For I<sup>2</sup>t = K Curve Only</b>			
	Definite Maximum Time to Trip	600 to 65,500 Cycles	1 Cycle	±3 Cycles or ±10%
	Reset Time (Linear)	4 Minutes (From Threshold of Trip)	—	—
<b>Negative Sequence Overvoltage</b>				
47	Pickup #1, #2	4 to 100% ①	0.1%	±0.5 V or ±0.5%
	Time Delay #1, #2	1 to 8160 Cycles	1 Cycle	±2 Cycles

① Of nominal voltage.

② When DFT is selected, the time delay accuracy is ±2 cycles. When rms is selected, an additional time delay from 0 to +20 cycles may occur.

③ Of nominal voltage, maximum of 600 V. This function can only be enabled when the relay is configured in line-to-line VT and the 25 function is not enabled.

④ Accuracy applies for a nominal current range of 2.5 A to 6 A (5 A CT) or 0.5 A to 1.5 A (1 A CT).

⑤ Of nominal current for currents less than 14 A (2.8 A).

⑥ Accuracy applies for a nominal current range of 2.5 A to 6 A (5 A CT) or 0.5 A to 1.5 A (1 A CT), and for a pickup of >5%.

**TABLE 48. M-3410A INTER-TIE PROTECTIVE RELAY SET POINTS (CONTINUED)**

<b>DEVICE NUMBER</b>	<b>FUNCTION</b>	<b>SET POINT RANGES</b>	<b>INCREMENT</b>	<b>ACCURACY</b>
<b>Inverse Time Residual Overcurrent</b>				
51N	Pickup	0.50 to 6.00 A (0.10 to 1.20 A)	0.1 A	±0.1 A or ±3% (±0.02 A or ±3%)
	Characteristic Curves	Definite Time/Inverse Time/Very Inverse/Extremely Inverse/IEC		
	<b>Time Dial</b>			
	Standard Curves #1 – #4	0.5 to 11.0	0.1	±3 Cycles or ±10%
	IEC Curves #1 – #4	0.05 to 1.10	0.01	—
<b>Inverse Time Overcurrent, with Voltage Control or Voltage Restraint</b>				
51V	Pickup	0.50 to 12.00 A (0.10 to 2.40 A)	0.01 A	±0.1 A or ±3% (±0.02 A or ±3%)
	Characteristic Curves	Definite Time/Inverse/Very Inverse/Extremely Inverse/IEC Curves		
	Time Dial	0.5 to 11.0	0.1	±3 Cycles or ±10%
		0.05 to 1.10 (IEC Curves)	0.01	—
	Voltage Control (VC) or	4 to 150.0% ①	0.1%	±0.5 V or ±5%
	Voltage Restraint (VR)	Linear Restraint	—	—
<b>Phase Overvoltage</b>				
59	Pickup #1, #2	100 to 150% ①	0.1%	±0.5 V or ±0.5% (±0.02 A or ±3%)
	Time Delay	1 to 8160 Cycles	1 Cycle	±2 Cycles ②
<b>Ground Overvoltage</b>				
59G	Pickup	4 to 150% ①	1.0%	±0.5 V or ±0.5% (±0.02 A or ±3%)
	Time Delay	1 to 8160 Cycles	1 Cycle	±2 Cycles
	This function can only be enabled when the relay is configured in line-to-line VT and the 25 function is not enabled.			
<b>Peak Overvoltage</b>				
59I	Pickup	100 to 150% ③	0.1%	±3% ④
	Time Delay	1 to 8160 Cycles	1 Cycle	±3 Cycles
<b>VT Fuse-Loss Detection</b>				
60FL	A VT fuse-loss condition is detected by using the positive and negative sequence components of the voltages and currents. VT fuse-loss output can be initiated from internally generated logic or from input contacts.			
	Time Delay	1 to 8160 Cycles	1 Cycle	±2 Cycles
<b>Reconnect Enable Time Delay</b>				
79	Time Delay	2 to 65,500 Cycles	1 Cycle	±2 Cycles
	Reconnect timer starts when all outputs designated as trip outputs reset.			
<b>Over/Underfrequency</b>				
81	Pickup #1, #2, #3, #4	50.00 to 67.00 Hz (40.00 to 57.00 Hz ⑤)	0.01 Hz	±0.03 Hz
	Time Delay #1, #2, #3, #4	2 to 65,500 Cycles	1 Cycle	±2 Cycles or ±0.01%
	The pickup accuracy applies to 60 Hz models at a range of 57 to 63 Hz, and to 50 Hz models as a range of 47 to 53 Hz. The accuracy is ±0.15 Hz for a range of 52 to 57 Hz, and 63 to 67 Hz (for 60 Hz nominal) and 42 to 47 Hz and 53 to 57 Hz (for 50 Hz nominal).			
<b>Nominal Settings</b>				
	Nominal Voltage	50 to 500 V ⑥	1 V	—
	Nominal Current	0.50 to 6.00 A	0.01 A	—
	VT Configuration	Line-Line/Line-Ground/Line-Ground-to-Line-Line ⑦		
	Seal-in Delay	2 to 8160 Cycles	1 Cycle	±1 Cycle or ±1.0%

- ① Of nominal voltage.
- ② When DFT is selected, the time delay accuracy is ±2 cycles. When rms is selected, an additional time delay from 0 to +20 cycles may occur.
- ③ Instantaneous voltage magnitude response; intended for ferroresonance protection.
- ④ For fundamental (60 Hz/50 Hz) signal only. For distorted input signals, the accuracy degrades as the order of harmonic signal increases.
- ⑤ This range applies to 50 Hz nominal frequency models.
- ⑥ Maximum measured range for (25), (59), (59G) and (59I) function settings is ≤600 V.
- ⑦ When line-ground-to-line-line is selected, the relay internally calculates the line-line voltage from the line-ground voltages for all voltage-sensitive functions. When the line-ground-to-line-line selection is applied, the nominal voltage selection should be the line-line nominal voltage (not line-ground nominal voltage).

## Appendix C Transient Voltage Surge Suppression Device

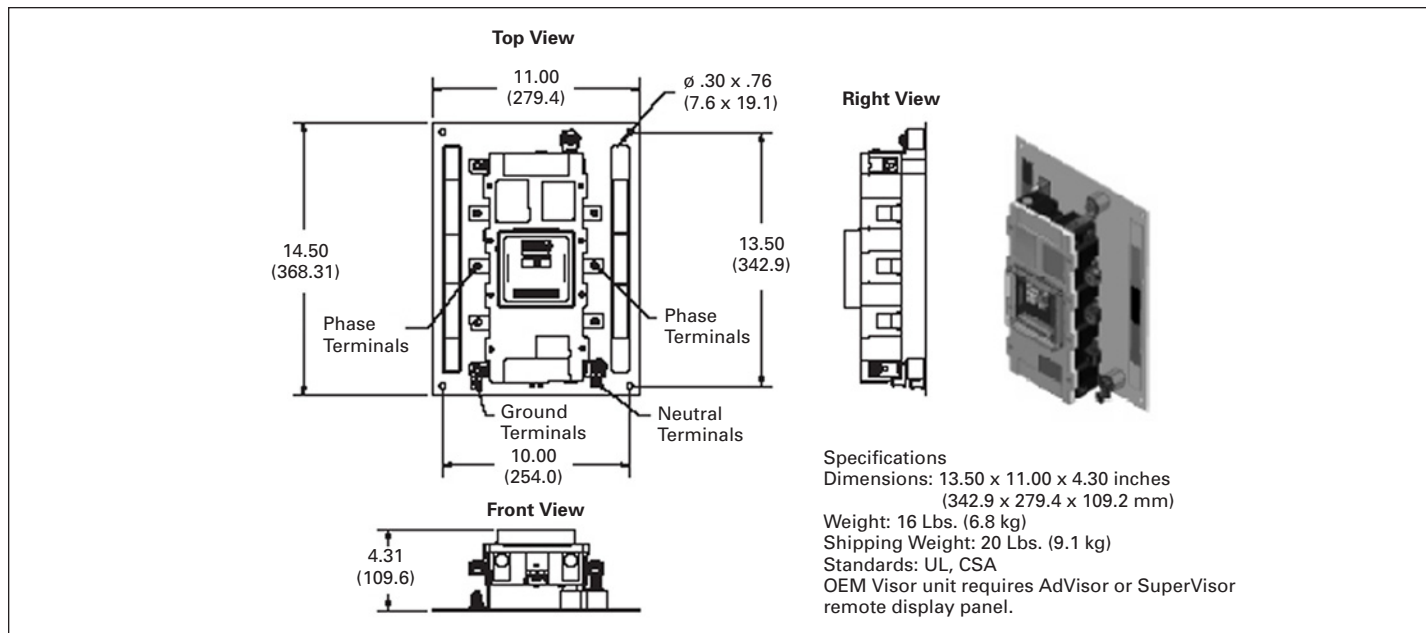


FIGURE 20. VISOR OEM 100, 100 AND 200 KA TECHNICAL DATA

### Technical Data

TABLE 49. VISOR SERIES — GENERAL PARAMETERS

DESCRIPTION	OEM VISOR
kA/Mode	50 – 250
kA/Phase	100 – 500
Split-Phase System	240 L, L, N, G
Wye System Voltages	120/208 277/480 347/600 L, L, L, N, G
Delta System Voltages	240 480 600 L, L, L, G
International System Voltages	127/220Y 230/400 L, L, L, N, G Mexico, other
Monitoring	AdVisor SuperVisor NetVisor
Mounting	Panelboards (PRL1A, 2A, 3A, 4) Remote Monitor Device Panel (Switchboard, Switchgear, Busway) MCC Version
Remote Display Cables <sup>Ⓢ</sup>	
Ribbon Cable	3 and 6 feet (0.9 and 1.8 m)
DB15 600 V Class Cable	8 and 16 feet (2.4 and 4.9 m)
Temperature	
Storage	-40°C to +60°C
Operation	-20°C to +60°C
Humidity (Relative)	5 – 95%
Warranty	10 years
Certifications/Listing	UL 1449 2nd Edition, CSA 22.2, UL 1283.

<sup>Ⓢ</sup> Remote display cables only for use on configuration B and Z models.

### Standards and Certifications

- All Visor Series units have been tested by UL and meet the requirements under UL 1449 2nd Edition for surge suppression devices.
- All Visor Series units have been tested as per NEMA LS-1 and ANSI/IEEE C62.45.
- Category A3 Ringwave (6 kV open circuit, 200 A short circuit current at 100 kHz).
- Category B3 Ringwave (6 kV open circuit, 500 A short circuit current at 100 kHz).
- Category C1 Combination Wave (6 kV 1.2/50us open circuits, 3 kA 8/20us short circuit current).
- Category C3 Combination Wave (20 kV 1.2/50us open circuits, 10 kA 8/20us short circuit current).
- UL 1020 (standard for safety for thermal cutoffs for use in electrical appliances and components).
- UL 1283 listed for EMI/RFI noise attenuation filtering (50 db at 100 kHz).
- CSA C22.2.

Dimensions are approximate in inches (mm).  
Should not be used for construction purposes.

## Magnum Closed Transition Soft Load Transfer Switches with ATC 5000 Controller



*Magnum Closed Transition Soft Load Transfer Switch with ATC 5000 Controller*

### Product Description

#### General Information

Electrical power generation located at or near the point of its consumption, commonly referred to as **Distributed Generation**, has seen tremendous growth recently due to factors such as limited utility grid generation and transmission capacity combined with the onset of utility deregulation. Strong economic incentives now exist for many users to consider on-site self generation for both improved power reliability and energy cost reduction. Additionally, these opportunities have spurred the development of new and unique types of generating and switching technologies.

Eaton Closed Transition Soft Load Automatic Transfer Switches are just such a technology. Closed transition soft load transfer switches are an ideal solution for power availability, energy management, and generator-set exercising applications. Unlike traditional open transition switches that provide a break-before-make operation, the closed transition soft load switch allows two power sources, usually the utility and a generator set, to be paralleled indefinitely. This permits the load, inductive or resistive, to be gradually and seamlessly transferred from one source to another. All of this is accomplished through the make-before-break operation of the switch with no power interruption to the load.

Eaton Closes Transition Soft Load Switch utilizes an integrated micro-processor based power controller to make active paralleling of two power sources possible. It manages the speed governor and voltage regulator of the generator set to bring the two sources into synchronization. This approach allows the transfer switch to be applied in soft load transfer applications. In addition, it can also be used as a peak shaving switch helping customers to reduce their peak demand charges by paralleling the generator set with the utility source during times of high electrical demand.

Standard fixed drawout or drawout bypass isolation configurations are available with or without an integral service entrance rating. If a switch with a service entrance rating is used as service entrance equipment, the need for separate service disconnects and overcurrent protective devices is eliminated.

Eaton Closed Transition Soft Load Automatic Transfer Switches are available for 800 through 3200 ampere, up to 600 Vac, 50 or 60 Hz applications worldwide. They are offered in both indoor (NEMA 1) and outdoor (NEMA 3R) free standing enclosures utilizing drawout or fixed insulated case Magnum DS switching devices. The Magnum DS switching device is a 100% rated device with a 100 kA interrupting capability at 600 Vac.

#### Application Description

Power reliability and power costs are two issues of strategic importance in almost all industry segments. Businesses have critical processes that cannot tolerate a shut down, while an extended failure in many cases could cause unrecoverable losses. In addition, significant changes in the utility industry have created on-site generation opportunities for customers to address their power reliability and energy

cost concerns. This type of on-site power generation at or near the point of consumption is known as distributed generation. Market studies estimate that over 40% of generation capacity added in the United States alone over the next 10 years will be distributed. A key enabler of these on-site generation systems and reliable power in general is often a closed transition soft load transfer switch.

Typical applications for Eaton Closed Transition Soft Load Automatic Transfer Switches include industrial processes, data centers and critical care facilities. Actually, any location with critical loads where the absence of power could result in lost revenue, production time, or personal injury should make this equipment a prime consideration.

#### Consider several specific applications:

- A facility with emergency or critical power systems wanting to test their generator sets without a power interruption.
- Any industrial, institutional, or commercial business seeking ways to lower energy costs by reducing demand charges, which can represent over 50% of an electrical bill.
- Energy Service Companies interested in offering performance based solutions to their customer base.
- Electrical power providers interested in offering power reliability solutions to their customer base in return for long term electrical contracts.

The Eaton Closed Transition Soft Load Automatic Transfer Switch can be applied in new installations or as a retrofit to replace an existing open transition transfer switch. A number of application issues should be reviewed. First, since most generator sets run on diesel fuel, there are exhaust emission concerns to consider. In some markets, the Environmental Protection Agency (EPA) limits the number of hours annually that a generator set can be operated. Methods to deal with such restrictions, should they present a problem, are the use of natural gas or dual fuel (natural gas/diesel mixture) types of generator sets. A second issue relates to electrical utility interconnection standards. Many utility companies require multiple levels of protective relaying when a user wishes to parallel to the utility grid. The cost of meeting some of these specifications can be high. These issues should be discussed when peak shaving is being considered.

### Features, Benefits and Functions

#### Sequence of Operations

##### Automatic Mode Operation — Transfer Switch Loss of Normal Power

The system will continuously monitor the condition of the normal power supply. When the voltage or frequency of the normal source is sensed outside the user adjustable set points, and after an adjustable time delay to override momentary dips and/or outages, a contact shall close to initiate a starting of the emergency or stand-by source. Transfer to the alternate source shall take place upon attainment of adjustable pick-up voltage and frequency of the alternate source.

##### Return of Normal Power — Breaker Open Transition Logic Selected

When normal source has been restored and is within the pre-selected ranges for voltage and frequency and after a time delay to ensure the integrity of the normal power source, the load shall be transferred back to normal source in a break-before-make transfer scheme. The generator set will continue to run for a user adjustable time to allow the generator set to run unloaded for cool down, after which the engine will be shut down. Upon completion the system will then be ready for automatic operation.

##### Return of Normal Power — Breaker Closed Transition Logic Selected

When the normal source has been restored and is within the pre-selected ranges for voltage and frequency, and after an adjustable time-delay to ensure the integrity of the normal source, the load shall be transferred back to the normal source in a make-before-brake transfer scheme.

On completion of the time delay, the generator set bus will automatically synchronize with the utility service across the Source 1 (normal) breaker. When the two systems are synchronized, the Source 1 (nor-

mal) breaker will close and the Source 2 (emergency) breaker will open. The generator set will continue to run for a user adjustable time to allow the generator set to run unloaded for cool down, after which the engine will be shut down. Upon completion the system will then be ready for automatic operation.

### **Return of Normal — Breaker Interchange (Soft Load) Logic Selected**

When the normal source has been restored and is within the pre-selected ranges for voltage and frequency, and after an adjustable time-delay to ensure the integrity of the normal source, the load shall be transferred back to the normal source in a make-before-brake transfer scheme. On completion of the time delay, the generator set bus will automatically synchronize with the utility service across the Source 1 (normal) breaker. When the two systems are synchronized, the Source 1 (normal) breaker will close and the generator set will gradually transfer all loads to the utility.

On completion of the load transfer sequence the Source 2 (emergency) breaker will open. The generator set will continue to run for a user adjustable time to allow the generator set to run unloaded for cool down, after which the engine will be shut down. Upon completion the system will then be ready for automatic operation.

### **Peak Shaving**

The closed transition soft load transfer switch can be factory configured to automatically parallel to the utility. In this operation mode, the switch will be paralleled with the utility when the user adjustable load power level is exceeded for the predetermined amount of time.

## **Test Mode Operation**

### **Engine Run Test Mode**

To perform an engine run test, first place the System Test switch in the "Run" position. Next place the Auto/Test switch in the "Test" position. The engine start contact will close, the engine will start and the generator will produce nominal voltage and frequency. **Neither** Source 1 nor Source 2 breaker will be operated.

Returning either the System Test to "Off" position or Auto/Test switch to "Auto" position will remove the "Engine Start" command. The engine will shut down.

### **Transfer Test Mode (Open Transfer)**

This operation is carried out when the controller's Breaker Logic is programmed for Open Transition via ATC-5000 Input 64.

To perform an open transition test, first place the Test Mode selector switch in the "Mode 1" position, followed by placing the System Test switch in "Test" position followed by placing Auto/Test selector switch in the "Test" position. After an adjustable time delay, the generator will start. After the nominal voltage and frequency are reached, the Source 1 (normal) breaker will open and the Source 2 (emergency) breaker will close on the dead bus.

Returning either the Auto/Test selector switch to "Auto" position or the Test Mode selector switch to "Off" position will cause the system to return to normal power as described in "Return Of Normal Power — Breaker Open Transition Logic Selected."

### **Transfer Test Mode (Closed Transition)**

This operation is carried out when the controller's Breaker Logic is changed to Closed Transfer via ATC-5000 Input 64.

To perform a closed transition test, first place the Test Mode selector switch in the "Mode 2" position, followed by placing the System Test switch in "Test" position followed by placing the Auto/Test selector switch in the "Test" position. After an adjustable time delay, the generator will start. After the nominal voltage and frequency are reached, the generator bus will be synchronized to the utility across the Source 2 (emergency) breaker. When the two sources are synchronized the Source 2 (emergency) breaker closes and then Source 1 (normal) breaker opens.

Returning either the Auto/Test selector switch to "Auto" position or the System Test selector switch to "Off" position will cause the system to return to normal power as described in "Return Of Normal Power — Breaker Closed Transition Logic Selected."

### **Transfer Test Mode (Interchange — Soft Load Transition)**

This operation is carried out when the controller's Breaker Logic is programmed for Interchange (Soft Load Transition).

To perform an interchange (soft load transition) test, first place the Test Mode selector switch in the "Mode 1" position, followed by placing the System Test switch in "Test" position followed by placing the Auto/Test selector switch in the "Test" position. After an adjustable time delay, the generator will start. After the nominal voltage and frequency are reached, the generator bus will be synchronized to the utility across the Source 2 (emergency) breaker. When the two sources are synchronized the Source 2 (emergency) breaker is closed and the generator gradually assumes all load. On completion of the load transfer sequence the Source 1 (normal) breaker will open.

Returning either the Auto/Test selector switch to "Auto" position or the System Test selector switch to "Off" position will cause the system to return to normal power as described in "Return of Normal Power (Switch in Closed Transition Mode)."

### **Paralleling Test mode (Baseload)**

This operation is carried out when the controller's Breaker Logic is changed to Parallel via ATC-5000 Input 64 and the Baseload operation is selected.

To perform a paralleling test in a base load mode, first place the Test Mode selector switch in the "Mode 2" position, followed by placing the System Test switch in "Test" position followed by placing the Auto/Test selector switch in the "Test" position. After an adjustable time delay, the generator will start. After the nominal voltage and frequency are reached, the generator bus will be synchronized to the utility across the Source 2 (emergency) breaker. When the two sources are synchronized the Source 2 (emergency) breaker is closed and the generator gradually assumes load up to the user programmable power level and then continuously maintains its power output.

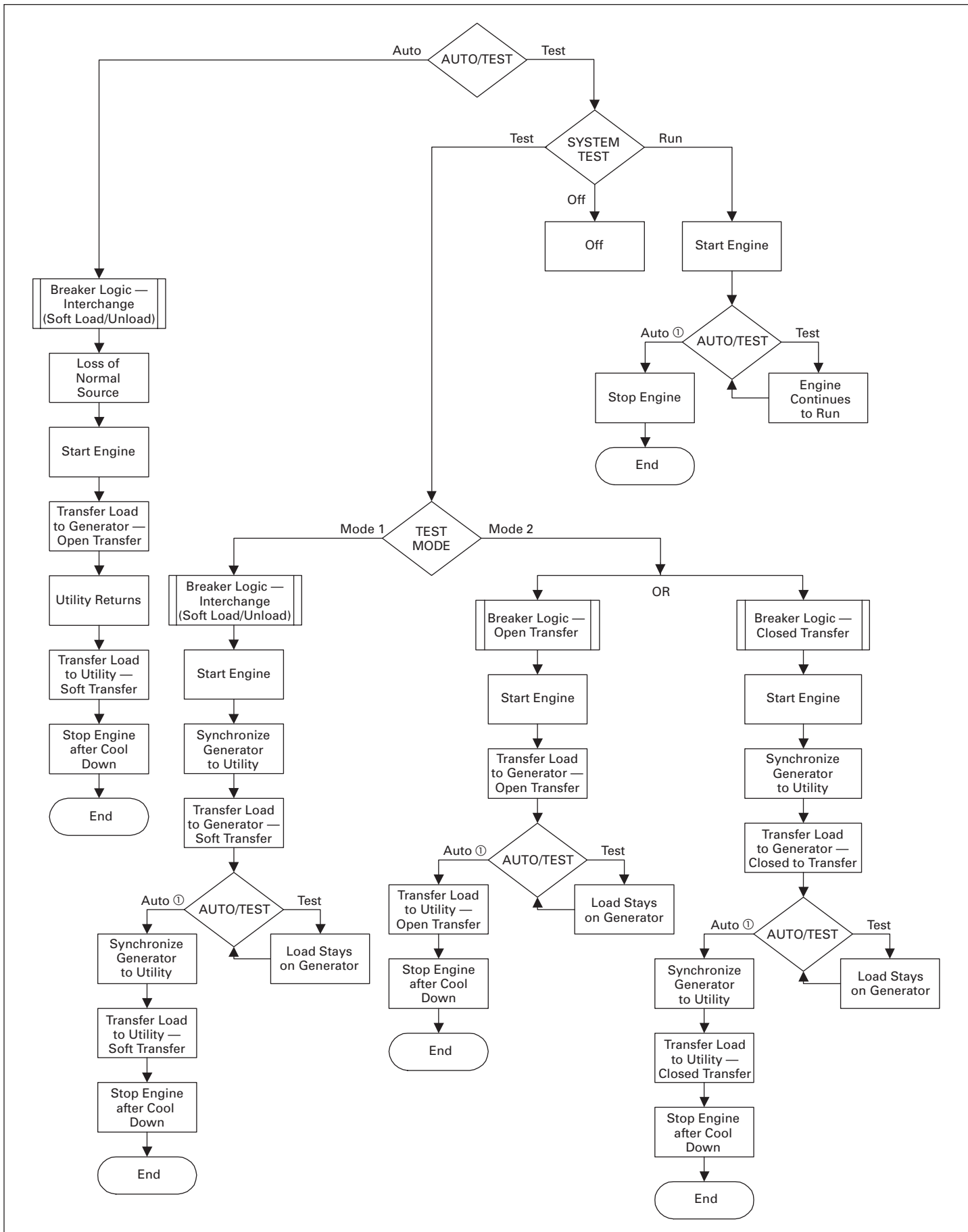
Returning either the Auto/Test selector switch to "Auto" position or the System Test selector switch to "Off" position will cause the generator to gradually unload and then the Source 2 (emergency) breaker will open. The generator set will continue to run for a user adjustable time allowing the generator set to run unloaded for cool down, after which the engine will be shut down. Upon completion the system will then be ready for automatic operation.

### **Paralleling Test Mode (Import/Export)**

This operation is carried out when the controller's Breaker Logic is changed to Parallel (via ATC-5000 Input 64 and the Import/Export operation is selected.

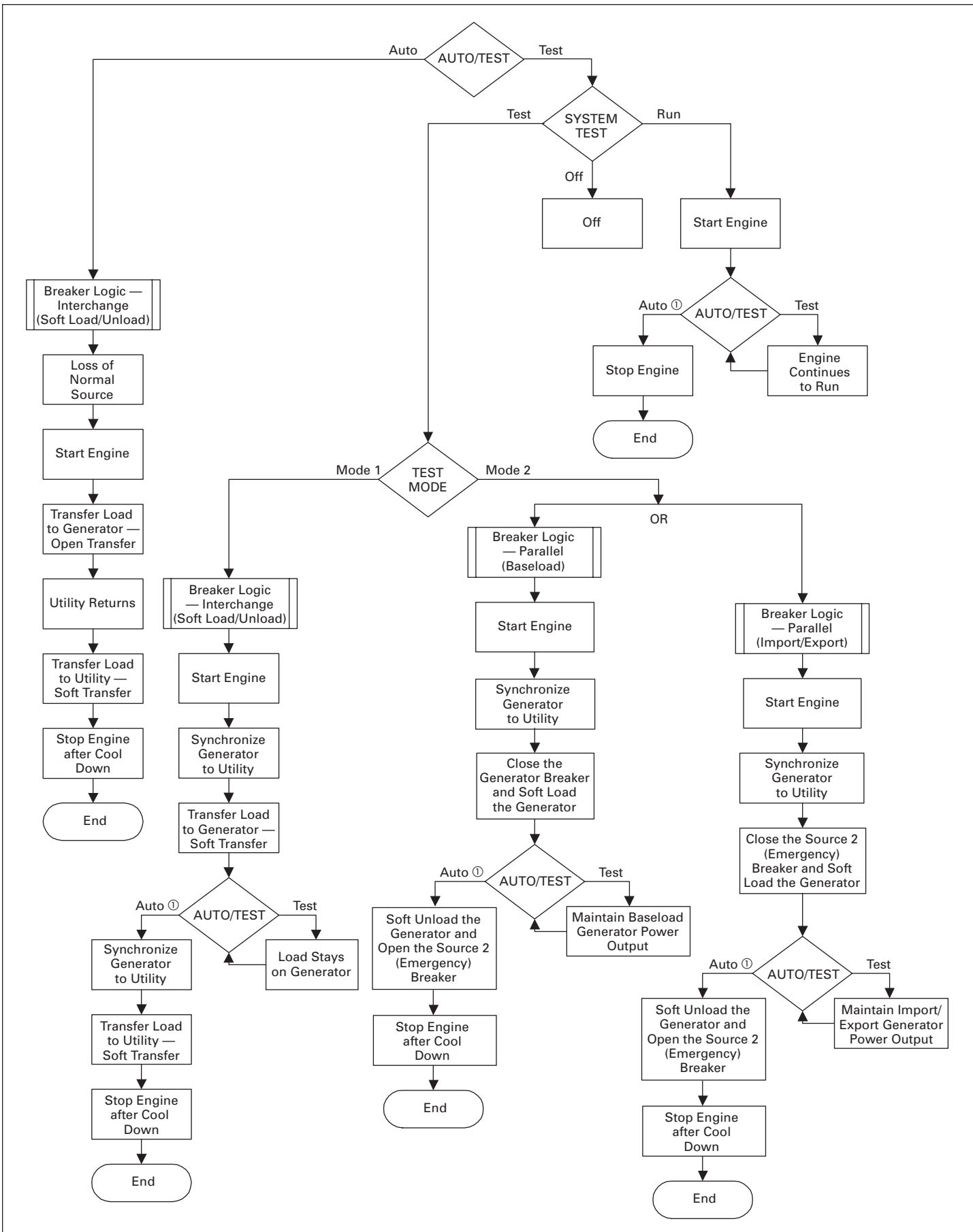
To perform a paralleling test in Import/Export mode, first place the Test Mode selector switch in the "Mode 2" position, followed by placing the System Test switch in "Test" position followed by placing the Auto/Test selector switch in the "Test" position. After an adjustable time delay, the generator will start. After the nominal voltage and frequency are reached, the generator bus will be synchronized to the utility across the Source 2 (emergency) breaker. When the two sources are synchronized the Source 2 (emergency) breaker is closed and the generator gradually assumes load up to the user programmable import (adjustable power setting for power supplied from the utility) or export (adjustable power setting for power supplied to the utility) power level and then continuously varies its power output to maintain the selected power flow.

Returning either the Auto/Test selector switch to "Auto" position or the System Test selector switch to "Off" position will cause the generator to gradually unload and then the Source 2 (emergency) breaker will open. The generator set will continue to run for a user adjustable time allowing the generator set to run unloaded for cool down, after which the engine will be shut down. Upon completion the system will then be ready for automatic operation.



**FIGURE 21. SEQUENCE FLOW CHART — SOFT LOAD ATS**

① Or switch SYSTEM TEST selector switch to OFF.



**FIGURE 22. SEQUENCE FLOW CHART — SOFT LOAD ATS WITH EXTENDED PARALLELING CAPABILITIES**

① Or switch SYSTEM TEST selector switch to OFF.

## Technical Data and Specifications

### System

#### Standards

Eaton Soft Load ATs are listed in File E38116 by Underwriters Laboratories, under Standard UL 1008. This standard covers requirements for ATs intended for use in ordinary locations to provide for lighting and power as follows:

- A. In emergency systems, in accordance with articles 517 and 700 in the National Electrical Code (NEC), American National Standards Institute/National Fire Protection Association (ANSI/NFPA) 70 and the NFPA No. 76A and/or
- B. In stand-by systems, in accordance with Article 702 of the NEC and/or
- C. In legally required stand-by systems in accordance with article 701 of the NEC.

Eaton ATs are available to meet NFPA 110 for emergency and stand-by power systems, and NFPA 99 for health care facilities when ordered with the appropriate options.

Since Eaton ATs utilize specially designed switches and/or switching devices as the main power switching contacts, these devices must also be listed under the additional UL Standard 1066. UL utilizes two basic types of listing programs: a) Label Service and b) Re-examination. UL 1066 employs a label service listing program which requires an extensive follow-up testing program for listed devices. Standard UL 1008 for ATs lists devices under the re-examination program which only requires a continual physical re-examination of the components used in the product to insure consistency with the originally submitted device. Follow-up testing IS NOT required by UL 1008.

Representative production samples of switches and switching devices used in Eaton ATs are subjected to a complete test program identical to the originally submitted devices on an ongoing periodic basis per UL 1066.

The frequency of such a re-submittal can be as often as every quarter for a low ampere device.

## Environmental

### Seismic

With proper installation and by including Option 42 which includes specially designed cleats, the Magnum transfer switch is a Seismic Certified Transfer Switch with certificate for application that is Seismic Zone 4 under the California Building Code, the Uniform Building Code, and BOCA.

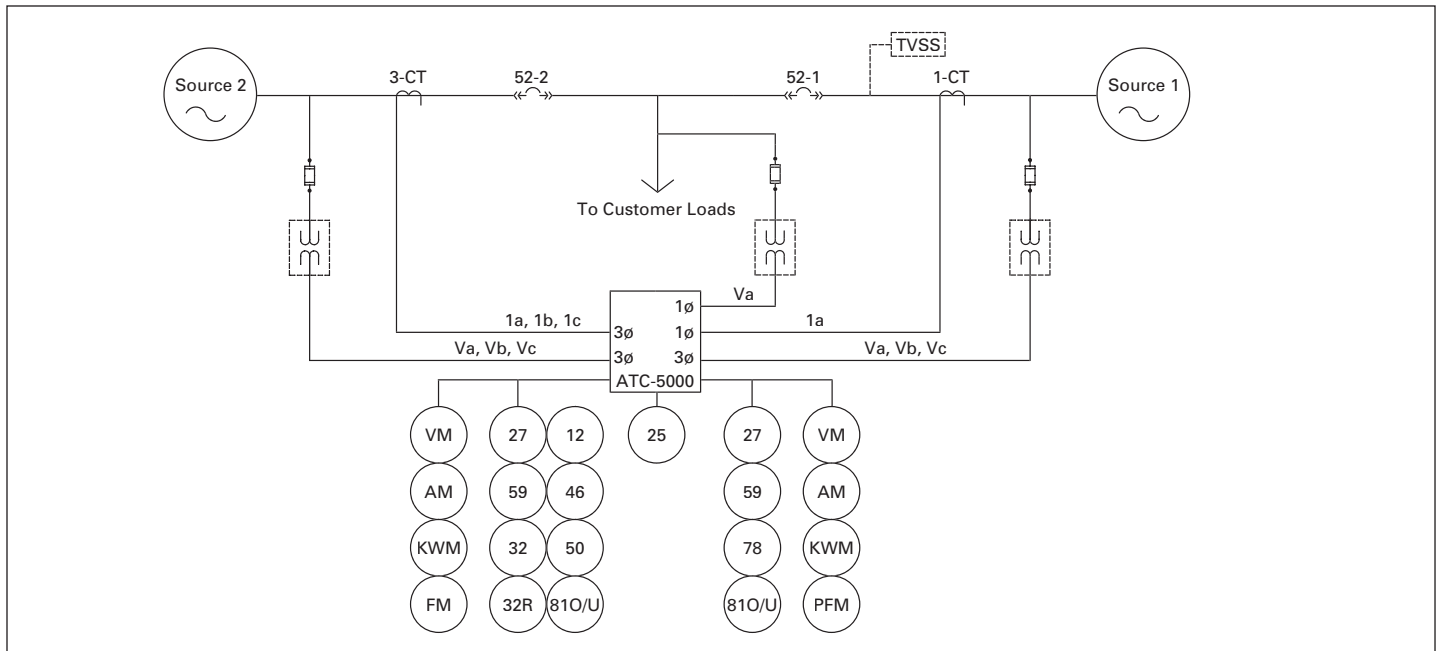
### Operational Conditions

Normal operation in an electrical equipment room for indoor applications. Outdoor applications can subject units to falling rain, freezing temperatures, and 95% humidity (non condensing).

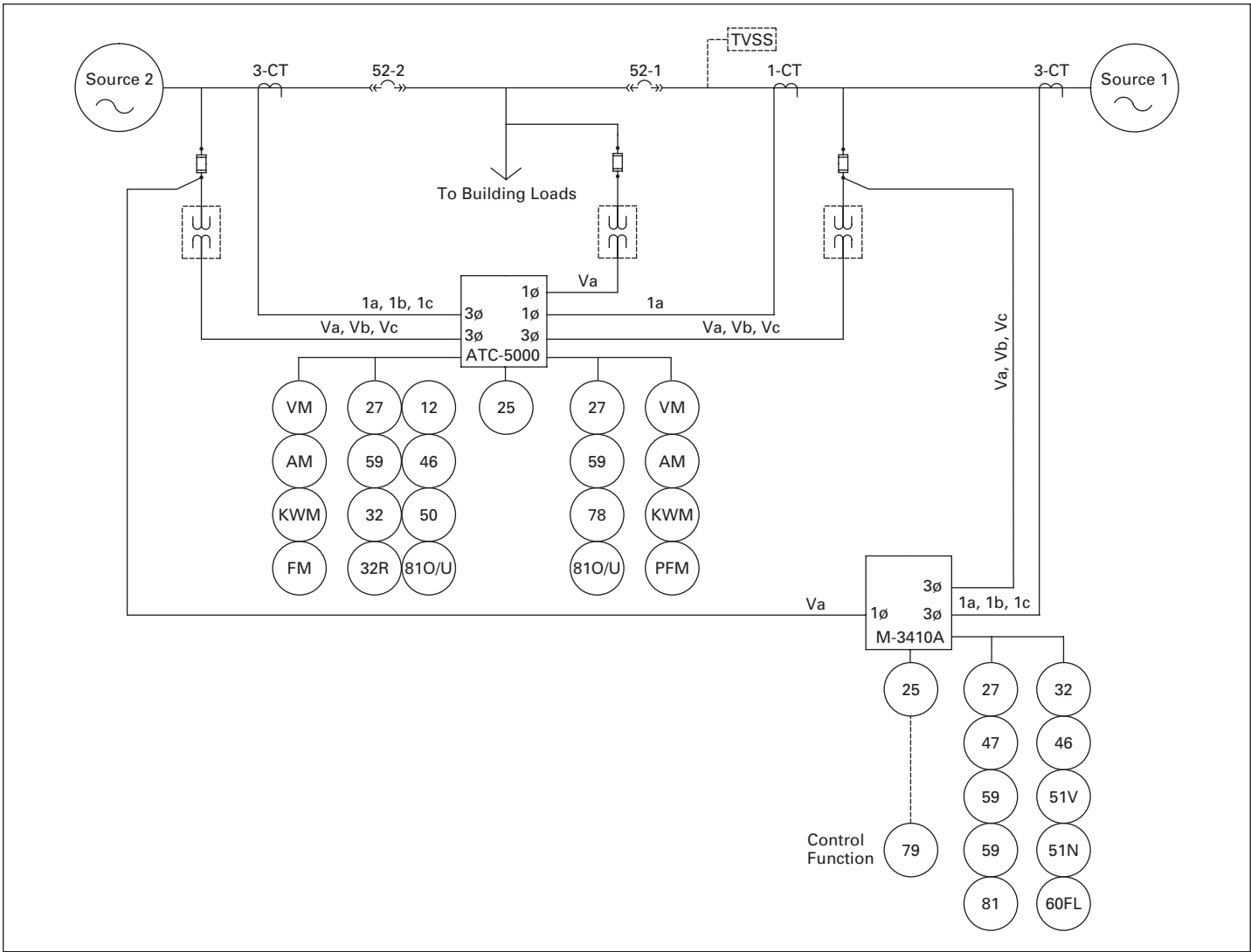
Ambient temperature for operation is between -20 and +65°C (-4 and 149°F).

**TABLE 50. SYSTEM RATINGS**

STANDARD UL 1008 3-CYCLE ATS AMPERE RATING	RATINGS WHEN USED WITH UPSTREAM BREAKER (KA)	30-CYCLE EXTENDED RATING RATINGS USED FOR COORDINATION WITH UPSTREAM BREAKERS WITH SHORT TIME RATING
	120 – 600 VAC	120 – 600 VAC
<b>Magnum DS Fixed and Drawout</b>		
800	100	85
1000	100	85
1200	100	85
1600	100	85
2000	100	85
2500	100	85
3200	100	85

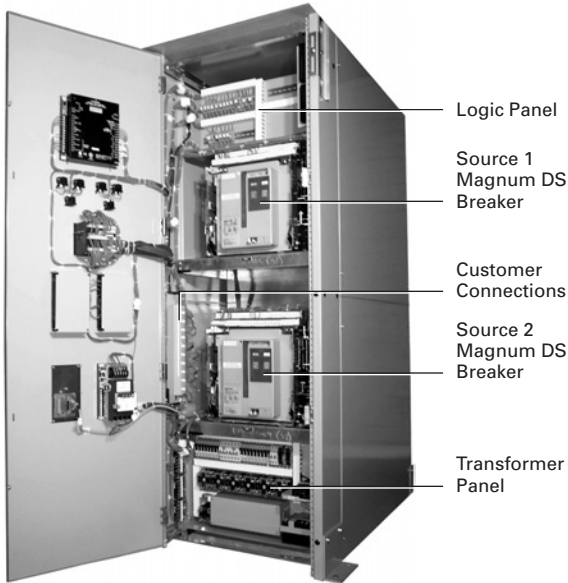
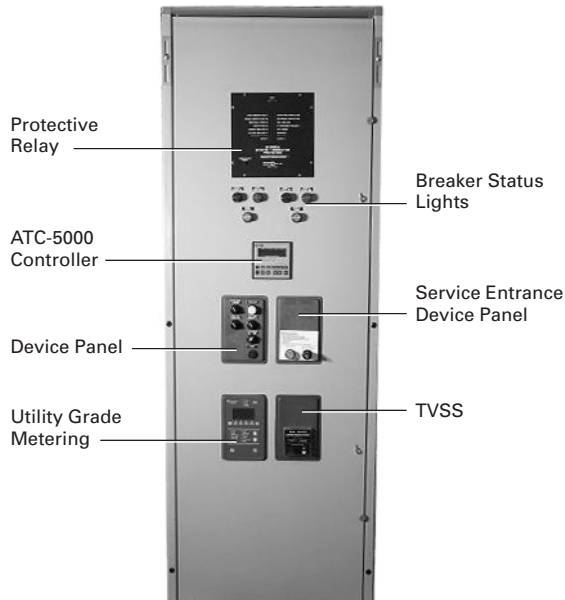


**FIGURE 23. Typical System Diagram — Standard One Line**



**FIGURE 24. TYPICAL SYSTEM DIAGRAM — STANDARD ONE LINE WITH UTILITY GRADE MULTI-FUNCTION RELAYING**

## Base Components



Magnum Soft Load ATS Base Components

## Enclosure

The rugged steel switch enclosure is supplied with four door hinges, regardless of enclosure size, to ensure proper support of the door and door mounted devices. The hinges have removable hinge pins to facilitate door removal. The doors are supplied as standard with thumbscrew and padlock latches. Cable entry holes are the customer's responsibility.

The door is used to mount a variety of lights, switches, and push buttons, depending upon the options required for a particular switch. All switch doors are supplied with a heavy duty plastic accessory panel in place, whether or not external devices are required. When lights, pushbuttons, or switches are required, they are normally mounted in the plastic door mounted panel.

Transfer switch enclosures and some internal steel mounting plates, such as the transformer panel mounting plate, go through a pre-treatment cleaning system prior to painting to insure a durable finish. Should the enclosure become scratched and in need of touch up paint, use ANSI 61. All remaining steel is galvanized.

The standard switch enclosure is NEMA Type 1 for general indoor use **Table 51**.

**TABLE 51. TRANSFER SWITCH EQUIPMENT ENCLOSURES**

NEMA TYPE	DESIGN	PROTECTION
1	Indoor	Enclosed Equipment
3R	Outdoor	Rain, Ice Formation

## Power Cables

Power cables are to be connected to solderless screw type lugs located on

the transfer switch switching devices. Refer to the separate Customer Wiring Diagrams supplied with the transfer switch equipment for power termination. Verify that the lugs supplied will accommodate the power cables being used. Also verify that the cables comply with local electrical codes. Standard transfer switch equipment, as supplied from the factory, will accommodate the wire sizes shown in **Table 52**.

**TABLE 52. WIRE SIZE FOR AVAILABLE POWER CABLE CONNECTIONS**

DEVICE	SWITCH AMPERE RATING	CABLES PER PHASE	RANGE WIRING SIZE
Switch	800 – 2000	6	3/0 – 750 kcmil
	2500 – 3200	9	3/0 – 750 kcmil
Neutral	800 – 2000	24	4/0 – 500 kcmil
	2500 – 3200	36	4/0 – 500 kcmil

**TABLE 53. DIMENSIONS CHART**

DESIGN	AMPERES	POLES	DIMENSIONS IN INCHES (MM)					
			NEMA 1			NEMA 3R		
			HEIGHT	WIDTH	DEPTH	HEIGHT	WIDTH	DEPTH
Fixed	800 – 2000	3 & 4	90.00 (2286.0)	32.00 (812.8)	48.00 (1219.2)	90.00 (2286.0)	32.00 (812.8)	54.00 (1371.6)
	2500 – 3200	3 & 4	90.00 (2286.0)	44.00 (1117.6)	48.00 (1219.2)	90.00 (2286.0)	44.00 (1117.6)	54.00 (1371.6)
Drawout	800 – 2000	3 & 4	90.00 (2286.0)	32.00 (812.8)	60.00 (1524.0)	90.00 (2286.0)	32.00 (812.8)	66.00 (1676.4)
	2500 – 3200	3 & 4	90.00 (2286.0)	44.00 (1117.6)	60.00 (1524.0)	90.00 (2286.0)	44.00 (1117.6)	66.00 (1676.4)
Fixed With Bypass Isolation	800 – 2000	3 & 4	90.00 (2286.0)	64.00 (1625.6)	48.00 (1219.2)	90.00 (2286.0)	64.00 (1625.6)	54.00 (1371.6)
	2500 – 3200	3 & 4	90.00 (2286.0)	88.00 (2235.2)	48.00 (1219.2)	90.00 (2286.0)	88.00 (2235.2)	54.00 (1371.6)
Drawout With Bypass Isolation	800 – 2000	3 & 4	90.00 (2286.0)	64.00 (1625.6)	60.00 (1524.0)	90.00 (2286.0)	64.00 (1625.6)	66.00 (1676.4)
	2500 – 3200	3 & 4	90.00 (2286.0)	88.00 (2235.2)	60.00 (1524.0)	90.00 (2286.0)	88.00 (2235.2)	66.00 (1676.4)

## Product Selection

### Transfer Switch Catalog Number Identification

Transfer switch equipment catalog numbers provide a significant amount of relevant information that pertains to a particular piece of equipment. The catalog number identification table (**Table 54**) provides the required interpretation information. An example for an open transition switch is offered to initially simplify the process.

**Example:** Catalog Number (circled numbers correspond to position headings in **Table 54**).

① to ② ③ ④ ⑤ to ⑥ ⑦ ⑧ ⑨ to ⑫ ⑬ ⑭ ⑮  
 CT V C MG E 3 2000 X R U

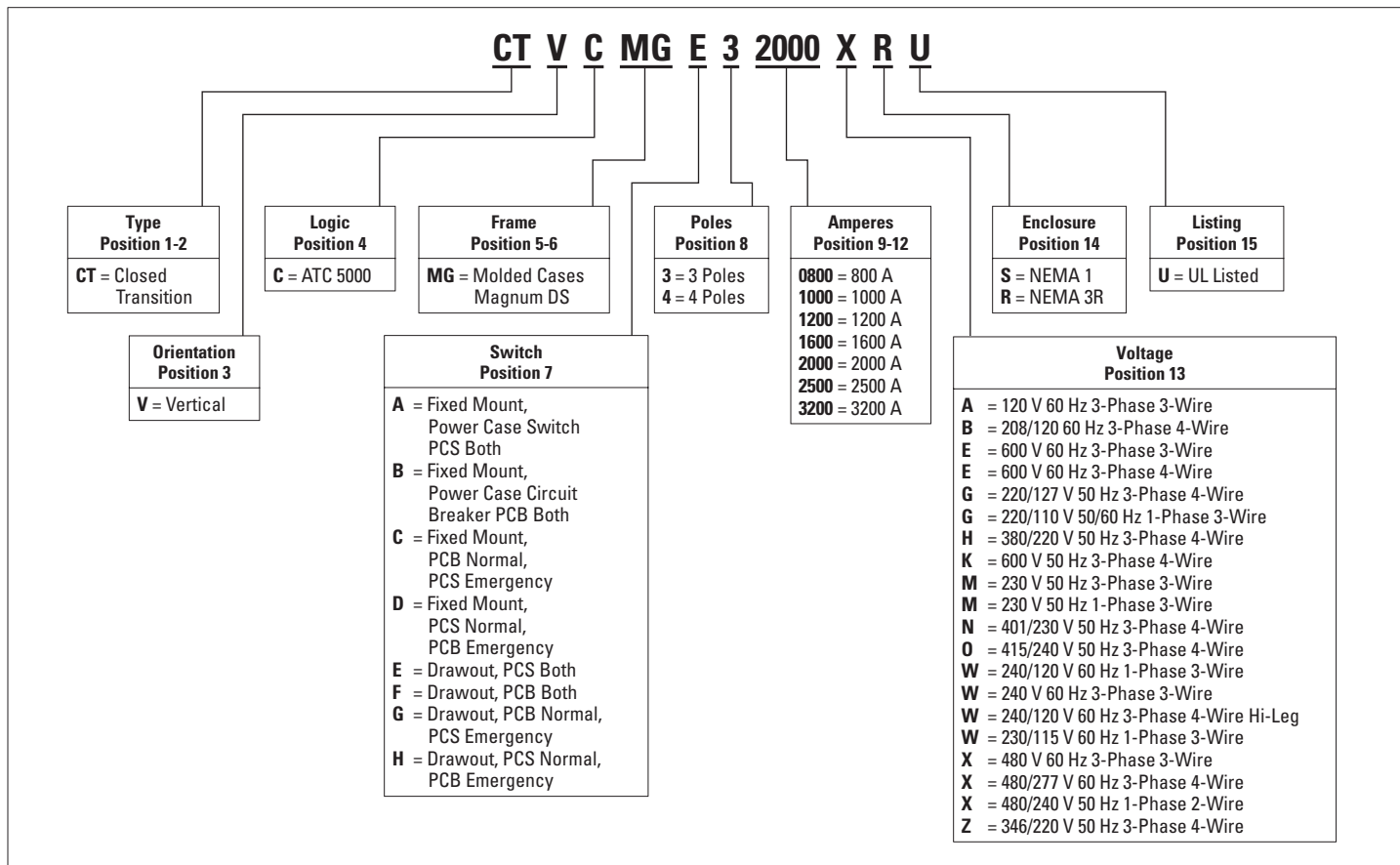
The catalog number CTVCMGE32000XRU describes a Soft Load ATS with the drawout switching devices mounted vertically in the enclosure. The intelligence, represented by the ATC-5000, is a microprocessor-based logic package.

The Magnum Breaker is used as the switching device and is a 3-pole molded case breaker for each source. The continuous current rating of this equipment is 2000 A and is applicable at 480/277 Vac, 60 Hz. The transfer switch equipment is enclosed in a NEMA 3R enclosure and is listed for Underwriters Laboratories (UL).

## Catalog Numbering System

**TABLE 54. TRANSFER SWITCH CATALOG NUMBER SYSTEM — MAGNUM SOFT LOAD TRANSFER SWITCHES 800 – 3200 AMPERES**

Using the Catalog Numbering System provides an overview of the ten basic style/feature categories which generate the 15 digit catalog number.



PCS = Power Case Switch  
 PCB = Power Circuit Breaker

## ATC-5000 Specifications



**ATC-5000 Integrated Microprocessor Controller**

The integrated logic controller is a microprocessor-based generator set control and management package. ATC-5000 provides a user-friendly interface allowing operators to easily view system status, view and reset alarms, display metered values and modify device set points.

The unit provides fully integrated communication to engine Electronic Control Units (ECUs) including:

- [via CAN bus] standard SAE J1939, Deutz EMR, Scania S6, mtu MDEC;
- [via RS-232] Caterpillar CCM to EMCP-II, and ECM.

### Features include:

- Integrated LED display.
- Automatic Transfer Switch Logic.
- True rms sensing.
- Frequency and Voltage Bias Outputs for the generator sets.
- Protective Relays.
  - Device 25A Synchronizer
  - Device 59/27 O/U Voltage for generator set and utility tie
  - Device 81 O/U Frequency for generator set and utility tie
  - Device 78 Phase/Vector shift for the utility tie
  - Device 32/32R Overload/Reverse Power for the generator set
  - Device 46 Load Imbalance for the generator set
  - Device 50/51 Overcurrent for the generator set
- Load Management.
  - Automatic base load/peak shaving
  - Import/Export power control
- Automatic Start/Stop sequencing for gas and diesel engines.
- Load dependent start/stop.
- Real Power/PF control.
- Counters for kWh, engine starts, operating hours and maintenance call.
- Freely configurable discrete and analog alarm inputs.
- Freely configurable relay and analog outputs.
- Language Manager.
- Event Logging.
- PC and front panel configurable.
- Multi level password protection.
- Battery voltage monitoring.
- CAN bus communication.

## Specifications

Accuracy	Class 1
Power supply	12/24 Vdc (9.5 to 32 Vdc)
Intrinsic consumption	Maximum 20 W
Ambient temperature	-20 to 70°C
Ambient humidity	95%, Non-condensing
<b>Voltage Rated</b> (Vrated):	[1] 69/120 Vac or [4] 231/400 Vac
UL:	[1] Maximum 86/150 Vac or [4] Maximum 173/300 Vac
Setting range(sec.)star:	[1] 50 to 125 Vac or [4] 50 to 480 Vac
Setting range(sec.)delta:	[1] 50 to 114 Vac or [4] 50 to 380 Vac
Setting range (prim.):	0.050 to 65,000 kVac
Measuring frequency	50/60 Hz (40 to 70 Hz)
Linear measuring range up to	1.3 $\nabla$ Vrated
Input resistance	[1] 0.21 MW, [4] 0.7 MW
Maximum power consumption per path.	<0.15 W
Current (rated values; Irated)	[./1]../1A or [./5]../5A
Current-carrying capacity	$I_{gen} = 3.0 \nabla I_{rated}$ $I_{mains} = 1.5 \nabla I_{rated}$
Load	<0.15 VA
Related short-time current (1s)	[./1] 50 $\nabla I_{rated}$ , [./5] 10 $\nabla I_{rated}$

### Discrete inputs

Input range	12/24 Vdc (6 to 32 Vdc)
Input resistance	Approx. 6.8 kW

### Analog inputs

Type	0/4 to 20 mA, Pt100, VDO
Resolution	10 Bit
Relay outputs	Potential free
Contact material	AgCdO
Load (GP)	2.00 Aac @ 250 Vac 2.00 Adc @ 24 Vdc/0.36 Adc @ 125 Vdc/ 0.18 Adc @ 250 Vdc

Pilot duty (PD)	B300 1.00 Adc @ 24 Vdc/0.22 Adc @ 125 Vdc/ 0.10 Adc @ 250 Vdc
-----------------	---

### Analog outputs

Type	0/4 to 20 mA, freely scaleable
Resolution	8/12 Bit (depending on model)
Maximum load 0/4 – 20 mA	500 W
Insulating voltage	1,500 Vdc

### Housing

Type	APRANORM DIN 43 700
Dimensions	144 $\nabla$ 144 $\nabla$ 118 mm
Front cutout	138[+1.0] $\nabla$ 138[+1.0] mm
Connection	Screw/plug terminals depending on connector 1.5 mm <sup>2</sup> or 2.5 mm <sup>2</sup>

Front	Insulating surface With proper installation
-------	--

### Protection system

Front	.IP42 (sealed IP45; gasket kit = P/N 8923-1039)
Back	.IP21

Weight	Depending on version, approx. 1,000g
--------	--------------------------------------

<b>Disturbance test</b> (CE)	Tested according to applicable EN guidelines
------------------------------	---

<b>Listings</b>	UL/cUL® listed (voltages up to 300 Vac)
-----------------	---

BOCA is a registered trademark of Building Officials and Code Administrators International, Inc. Cutler-Hammer is a federally registered trademark of Eaton Corporation. CSA is a registered trademark of the Canadian Standards Association. Gen-Tran is a registered trademark of Gen-Tran Corporation. ISO is the registered trademark and sole property of the International Organization for Standardization. National Electrical Code and NEC are registered trademarks of the National Fire Protection Association, Quincy, Mass. NEMA is the registered trademark and service mark of the National Electrical Manufacturers Association. Uniform Building Code (UBC) is a trademark of the International Conference of Building Officials (ICBO). UL and cUL are federally registered trademark of Underwriters Laboratories Inc. NFPA is a registered trademark of the National Fire Protection Association. Modbus is a registered trademark of Modicon, a division of Schneider Electric Industries SA.

Eaton Electrical Inc.  
1000 Cherrington Parkway  
Moon Township, PA 15108-4312  
United States  
tel: 1-800-525-2000  
[www.EatonElectrical.com](http://www.EatonElectrical.com)



**Cutler-Hammer**

© 2006 Eaton Corporation  
All Rights Reserved  
Printed in USA  
Publication No. TD01602016E / Z4771  
August 2006